

Instruction Manual

CT Series Cooling with EC1642 Tank Kit



CT Series Cooling with EC1606 Tank Kit

CT
Evaporative
Cooling System
with End Tank
EC1642 • EC1606

CT Evaporative Cooling System with End Tank

Models: CT10 • CT05 • CT04 • CT02



CT Evaporative Cooling System with End Tank

Instructions for Use and Maintenance

Thank You:

Thank you for purchasing a Munters CT Evaporative Cooling System. Munters equipment is designed to be the highest performing, highest quality equipment you can buy. With the proper installation and maintenance it will provide many years of service.

Please Note:

To achieve maximum performance and insure long life from your Munters product it is essential that it be installed and maintained properly. Please read all instructions carefully before beginning installation.

Warranty:

For Warranty claims information see the “Warranty Claims and Return Policy” form QM1021 available from the [Munters Corporation office at 1-800-227-2376](#) or by e-mail at aghort.info@munters.com.

Conditions and Limitations:

- Products and Systems involved in a warranty claim under the “Warranty Claims and Return Policy” shall have been properly installed, maintained and operated under competent supervision, according to the instructions provided by Munters Corporation.
- Malfunction or failure resulting from misuse, abuse, negligence, alteration, accident or lack of proper installation or maintenance shall not be considered a defect under the Warranty.

Index

Chapters	Page
1. Unpacking the Equipment	4
1.1 Parts List	4
1.2 Dimensions	4
2. Installation Instructions	5
2.1 Installation	5
3. Plumbing Installation	25
3.1 Black Poly Tank	25
3.2 White Pipe Tank	28
3.3 Optional Flush-out Kit (EC1507)	30
3.4 Cooling System Elevation Views	31
3.5 Plumbing Layout with Black Poly Tank	36
3.6 Plumbing Layout with White Pipe Tank	37
4. Operation	38
4.1 System Start-up	38
4.2 System Operation and Adjustment	38
5. Maintenance	39
5.1 Minimum Maintenance Schedule	39
5.2 Maintenance Checklist	39
6. Exploded View and Parts List	40-41

Unpacking the Equipment

1.

Before beginning installation, check the overall condition of the equipment. Remove packing materials, and examine all components for signs of shipping damage. Any shipping damage is the customer's responsibility and should be reported immediately to your freight carrier.

1.1 Parts List

Munters CT Evaporative Cooling Systems come in lengths from 5'L. to 80'L., sold in multiples of 5'L. and 10'L. modular sections. The ending kits, pumps, tank kits and plumbing kits will be packaged separately.

- A 10'L., 20'L., 30'L., ... 70'L. and 80'L. systems will arrive as multiples of 10'L. packages for the cooling frame and Ending Kit.
Example: 60'L. Cooling System
 - 6 - CT10, 10'L. Cooling Frame
 - 1 - EC4110, Ending Kit
 - 1 - Sealant Box
- A 5'L., 15'L., 25'L., ... 65'L. and 75'L. systems will arrive as multiples of 10'L. packages and one 5'L. package and Ending Kit.
Example: 65'L. Cooling System
 - 6 - CT10, 10'L. Cooling Frame
 - 1 - CT05, 5'L. Cooling Frame
 - 1 - EC4110, Ending Kit
 - 1 - Sealant Box

If optional add on kits are ordered, one or more extra box(s) marked CT02 or CT04 will be included.

1.2 Dimensions

Each CT System includes:

- 8" Pipe, PVC
- Drip Collector, PVC
- Drip Collector End Cap, PVC
- Distribution Cap, AL
- Pad Retainer, AL
- 1 1/2" Pipe with holes, PVC
- 1 1/2" Slip Cap, PVC
- 2 - End Panels, PL
- Pipe Support Brackets - supplied for 4' O.C. (see Chart A)
- 1 - Hardware Package
- 1 - Flush-out Kit (EC1507), purchased separately

NOTE: Tank Kits and Ending Kits must be purchased with each 'CT' Cooling System.

<u>Non-submersible pumps</u>	<u>Submersible pumps</u>
10" Tank: EC1607	15" Tank: EC1606
15" Tank: EC1608	15" Tank: EC1609
Black Poly Tank: EC1644	Black Poly Tank: EC1640
	Black Poly Tank: EC1642

NOTE: If EC1609 or EC1640, Center Tee Tank Kit was purchased, proceed to QM1134.

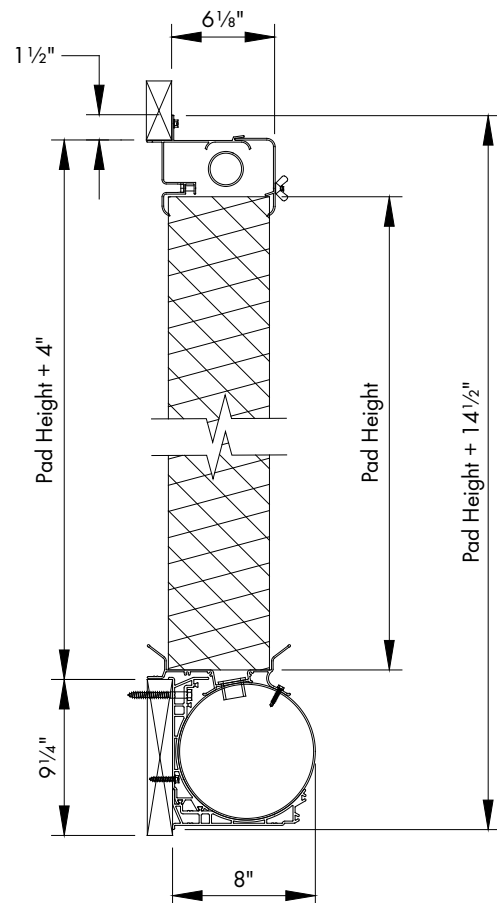

Installation Instructions

2.

2.1 Installation

NOTE: If a 'CH' height extension kit was ordered refer to step 1, page 2 in QM1135.

Step 1

Construct a wall opening according to your cooling system size, with studs 2' O.C. or posts 4' O.C. (max 5' O.C.). *See Figure 1.* (For example a CT36 with 5' Pad would have an opening of 36' - 1/2" L. x 64" H.).

NOTE: If metal framing is required, replace all 2x treated framing with 'C' channel or tube steel. Framing should be Aluminum or painted galvanized. *See Figure 4C* on page 7.

Pad Height	Wall Opening Height
24"H.	28"H.
36"H.	40"H.
48"H.	52"H.
60"H.	64"H.
72"H.	76"H.

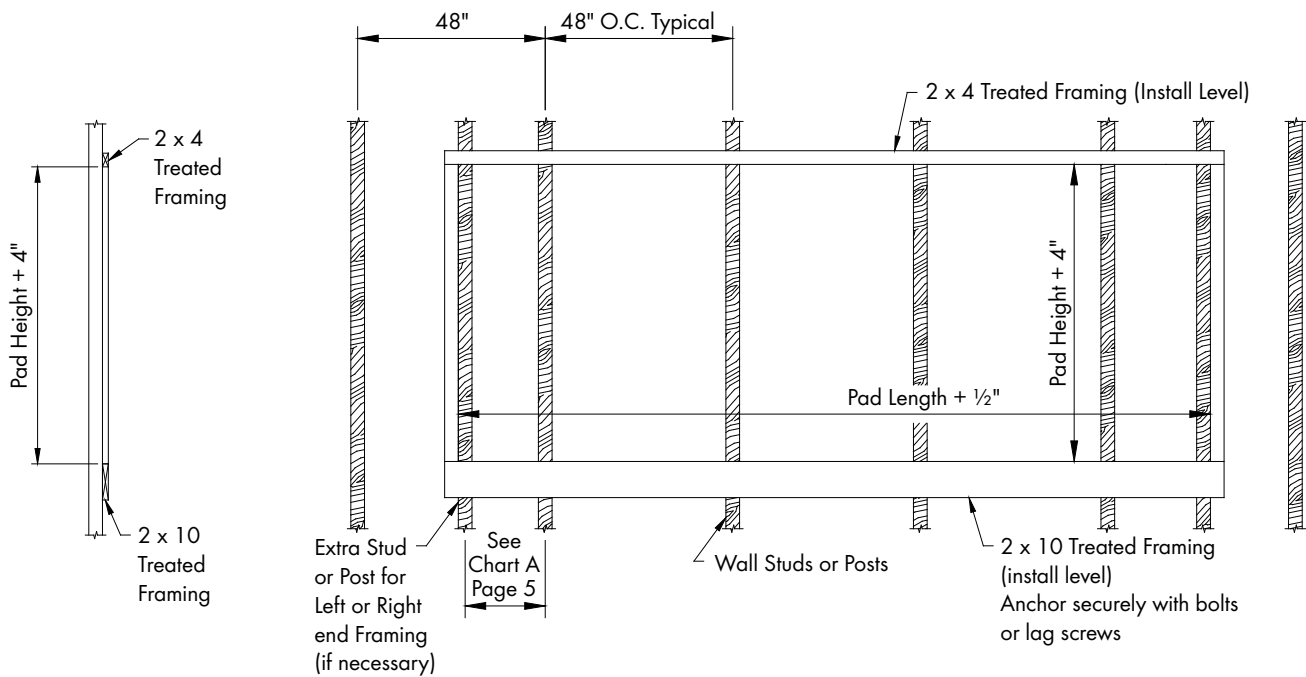

Figure 1

Step 2

Some Brackets are in the ending kit and some are in the cooling kit. Find 2 halves of the Pipe Bracket, EC1330 and slide them together. *See Figure 2.*

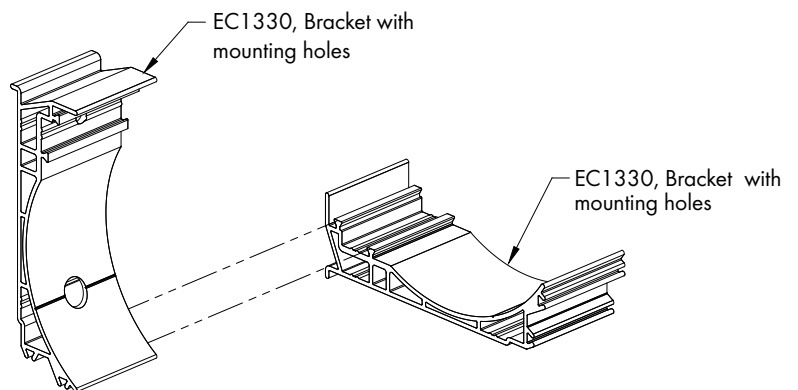

Figure 2

Step 3

For proper Pipe Support Bracket spacing refer to *Chart A, Figures 3A and 3B.*

Chart A

Length of Cooling System	No. of Brackets Needed	Placement of Brackets *
4'	2	2"
5'	2	12"
6'	2	12"
8'	3	2"
10'	3	12"
12'	4	2"
14'	4	12"
15'	5	2"
16'	5	2"
18'	5	12"
20'	6	2"
22'	6	12"
24'	7	2"
25'	7	12"
26'	7	12"
28'	8	2"
30'	8	12"
32'	9	2"
34'	9	12"
35'	10	2"
36'	10	2"
38'	10	12"
40'	11	2"
42'	11	12"
44'	12	2"
45'	12	12"
46'	12	12"
48'	13	2"
50'	13	12"
52'	14	2"
54'	14	12"
55'	15	2"
56'	15	2"
58'	15	12"
60'	16	2"
62'	16	12"
64'	17	2"
65'	17	12"
66'	17	12"
68'	18	2"
70'	18	12"
72'	19	2"
74'	19	12"
75'	20	2"
76'	20	2"
78'	20	12"
80'	21	2"

***** IMPORTANT *****
 The tee and cap or tank must be evenly sitting on the ground or supported securely on a level surface.

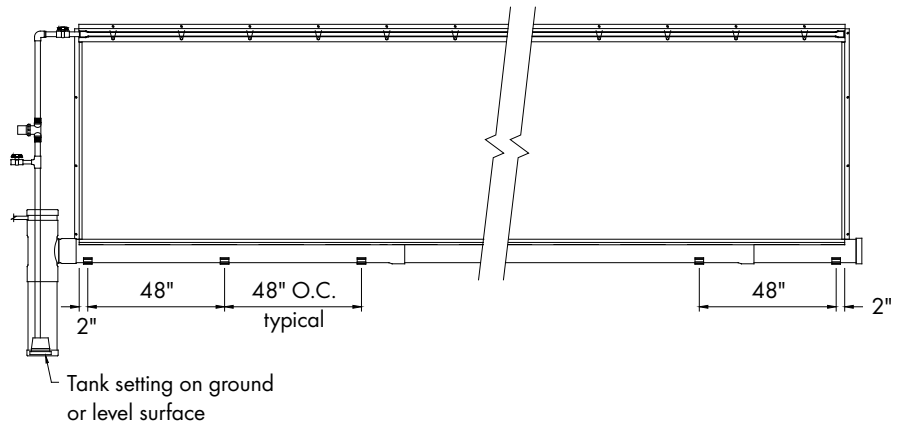

Figure 3A
 Shown with White Pipe Tank

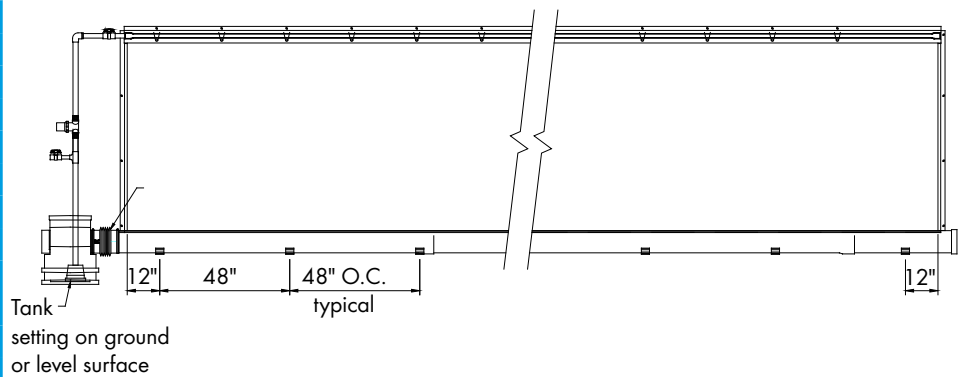

Figure 3B
 Shown with Black Poly Tank

Step 4

At the bottom framing fasten the Pipe Support Bracket to the 2 x 10 at each post (stud) according to the proper spacing on [Chart A](#). Make sure the lip of the Pipe Support Bracket hangs on the top of the 2 x 10. The top hole of the Pipe Support Bracket should be secured with a 3/8" x 3 1/2" Lag Screw (provided). Pre-drill framing for 3/8" Lag Screws using 1/4" drill bit. The bottom hole should be fastened with a #14 x 1 1/2" Lag Screw (provided). See [Figure 4A, 4B or 4C and 4D](#). If framing does not match [Figure 4A](#), framing must be capable of supporting 300 lbs. per bracket.

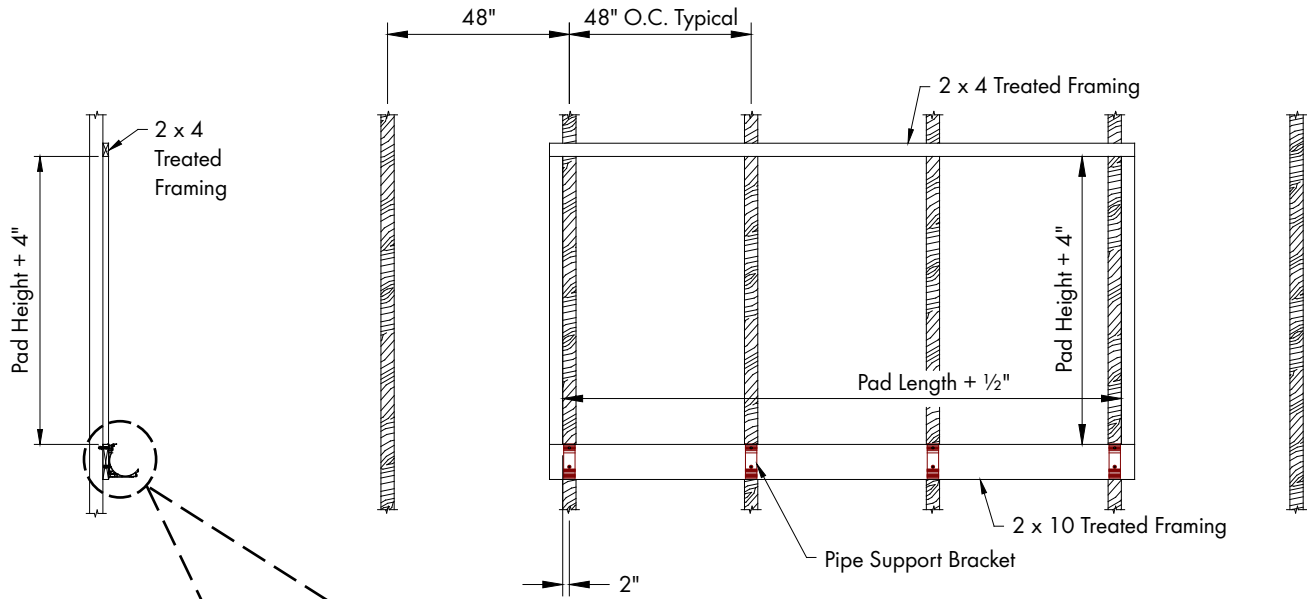

Figure 4A

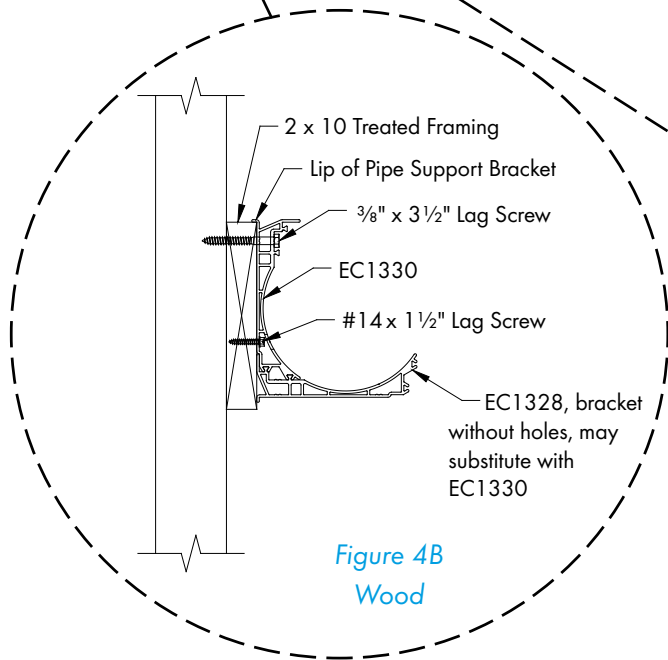

Figure 4B
Wood

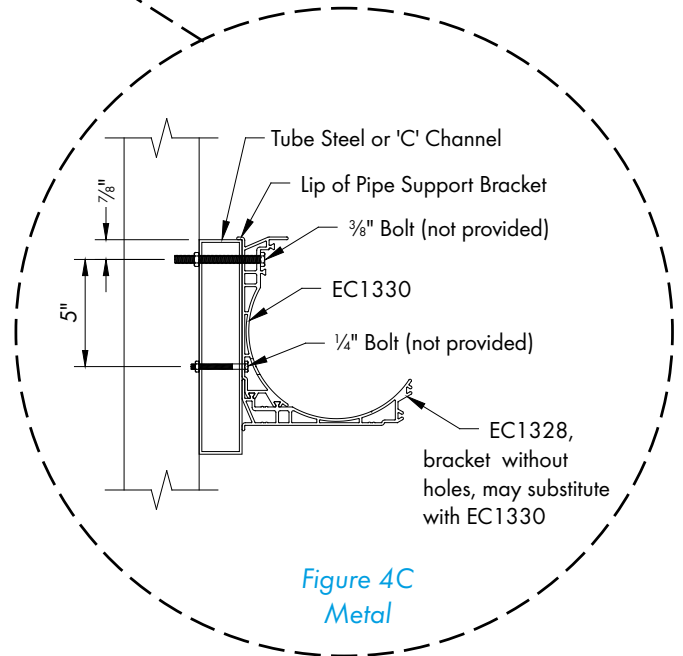

Figure 4C
Metal

Step 5

Starting on the end that the tank will mount on, position first 2 sections of 8" Pipe in Pipe Support Brackets. Prepare the pipe with PVC Pipe Primer, following directions of use and drying. After priming, use heavy duty, heavy bodied PVC cement for pipe 8" diameter or larger, in accordance to the PVC cement directions.

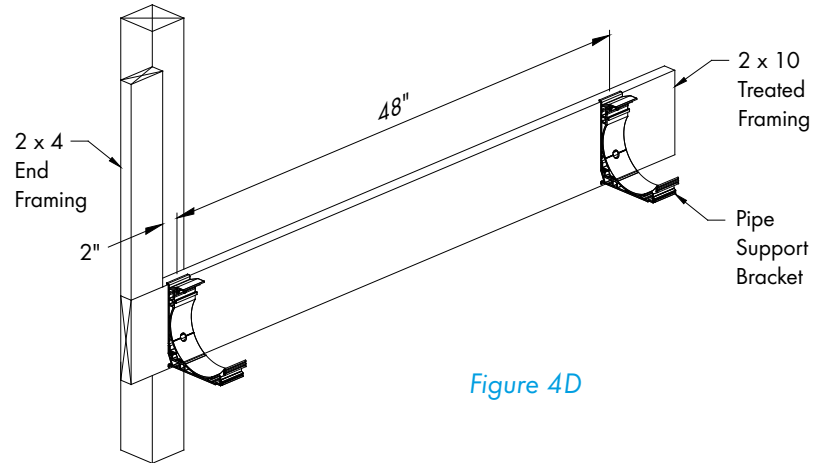

Figure 4D

Step 6

Apply a generous amount of PVC cement to the inside of the belled end, and the outside of the male end, and slide together, 5" deep. See Figure 5A. Continue for all sections of 8" pipe.

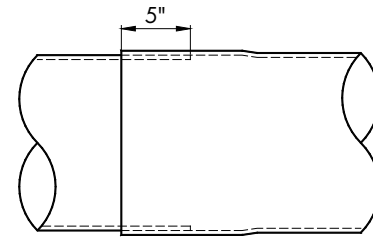

Figure 5A

Step 7A

On the end that the tee will mount extend the 8" pipe 4" past the edge of the framed opening. See Figure 5B.

Step 7B

On end opposite the tee, cut the 8" pipe off 4" past the framed opening. See Figure 5B.

Step 8

Set the first drip collector on the 8" pipe, leaving a 1/8" gap between edge of frame opening and drip collector. Place a level across drip collector flanges and level drip collector front to back. See Figure 6A.

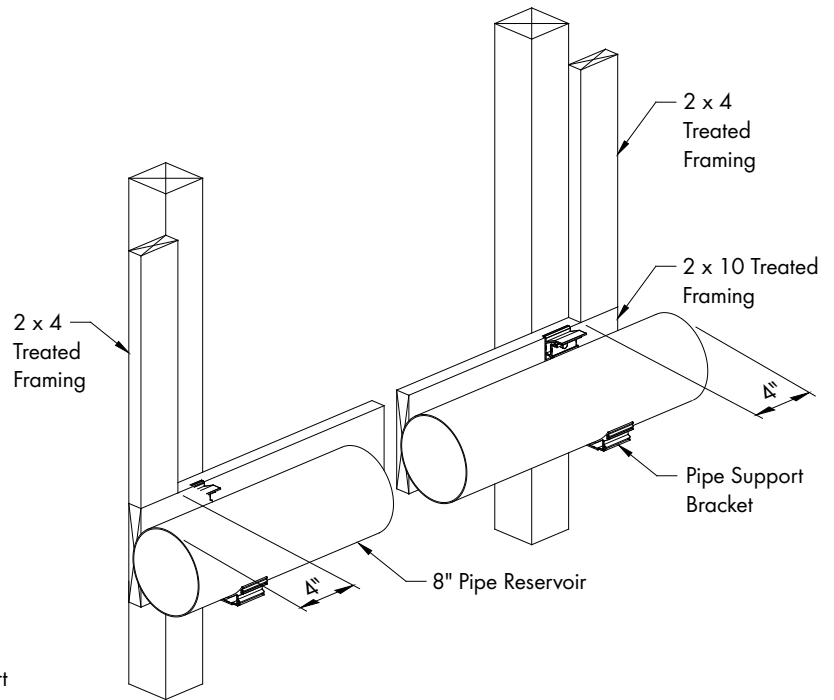

Figure 5B

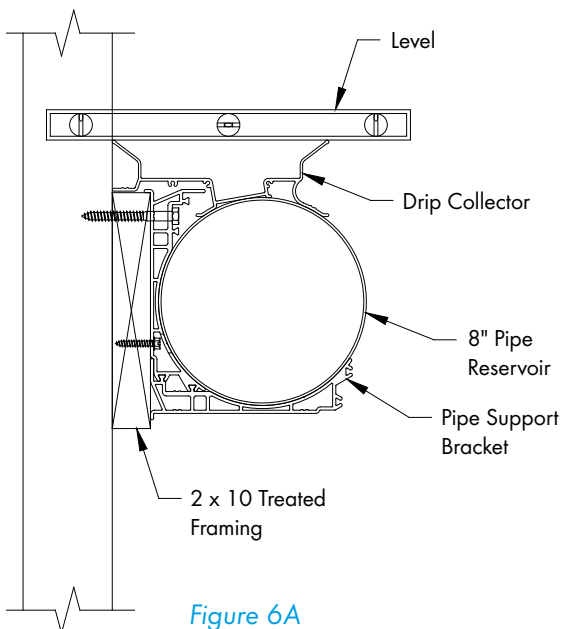

Figure 6A

Step 9

Carefully lift end of Drip Collector off 8" Pipe. Prime and PVC cement a 3" wide area on 8" Pipe, at both ends of Collector. Replace drip collector on the 8" Pipe, keeping it level. Fasten each end of Collector to 8" Pipe using (1) #10 x 1/4" TEK Screw located 4" from each end. See Figure 6B and 6C.

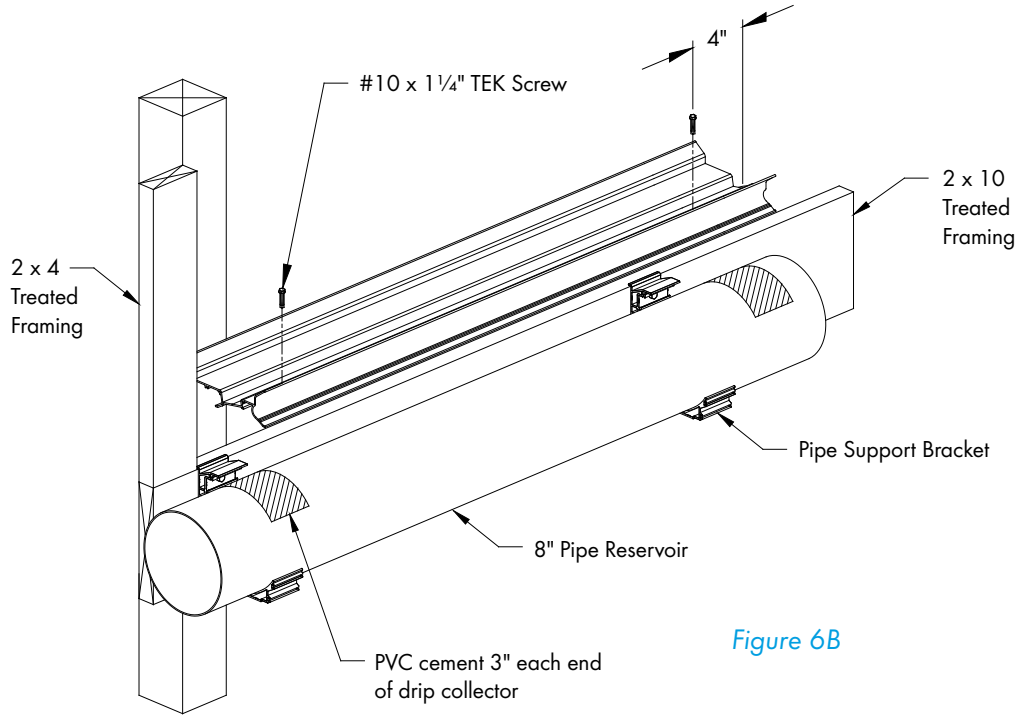

Figure 6B

Step 10A

Starting 2" from left end of the Drip Collector, keeping Drip Collector level, fasten to 8" Pipe using #10 x 1/4" TEK Screw (provided). Continue fastening Drip Collector to 8" Pipe using #10 x 1/4" TEK Screws at 16" O.C., use the V-groove as a guide. See Figures 7A and 7B.

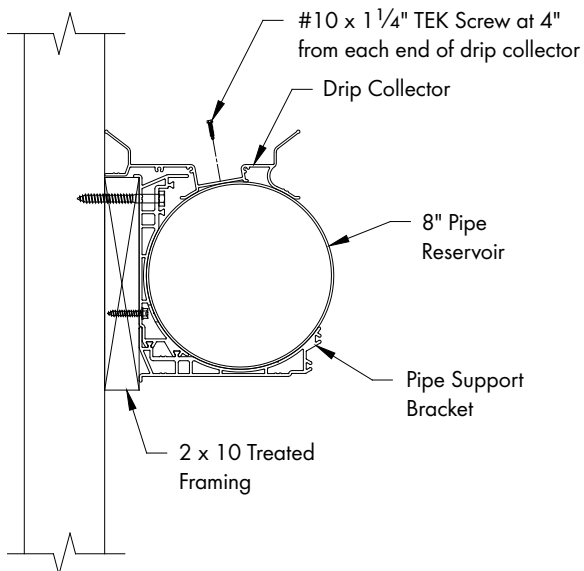

Figure 6C

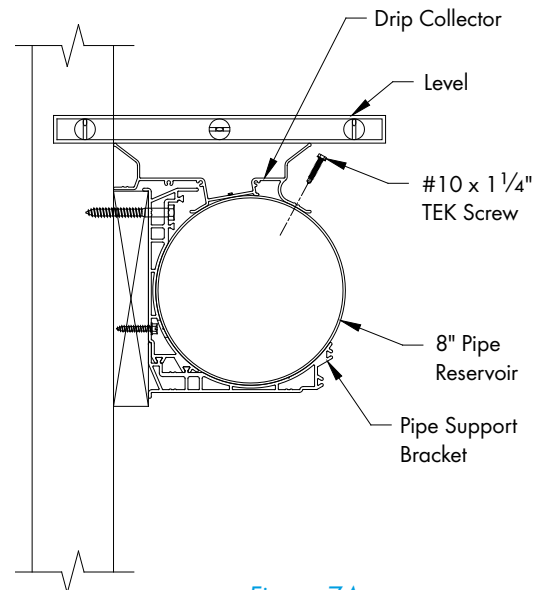

Figure 7A

Step 10B

Continue placing Drip Collectors down length of pipe by leveling, priming, cementing and fastening drip collectors to 8" Pipe. Be sure to push Drip Collectors tight together. See Figure 7B.

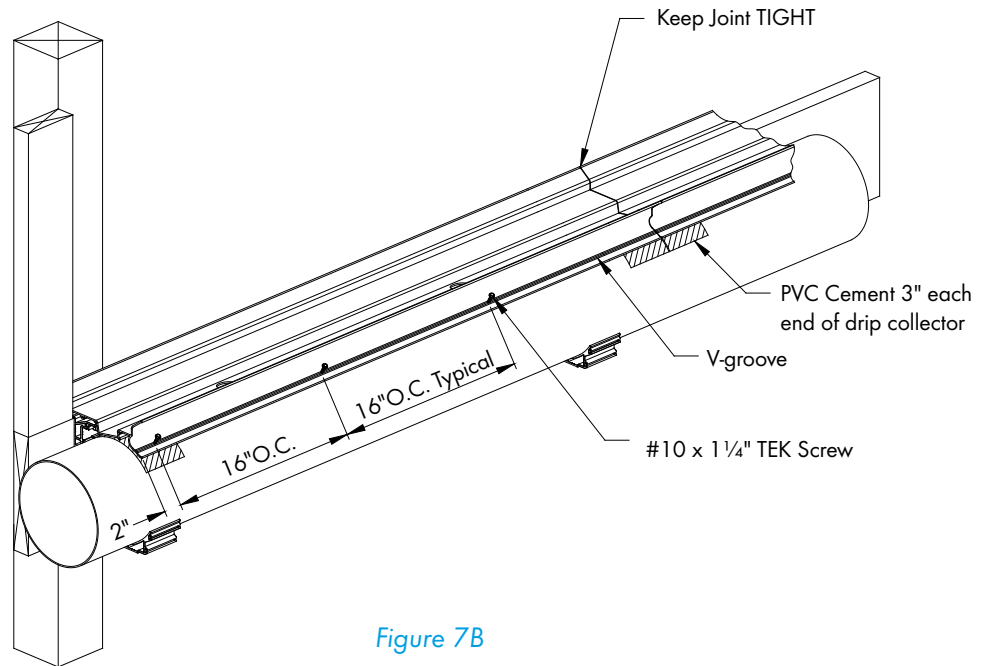

Figure 7B

Step 10C

Prime and PVC cement Drip Collector 3" on each side of joint. Center Splice over joint in Drip Collector and fasten in place using (6) #10 x 1 1/4" TEK Screws. Locate (2) in bottom of Splice and (2) on each flange. See Figures 7C and 7D.

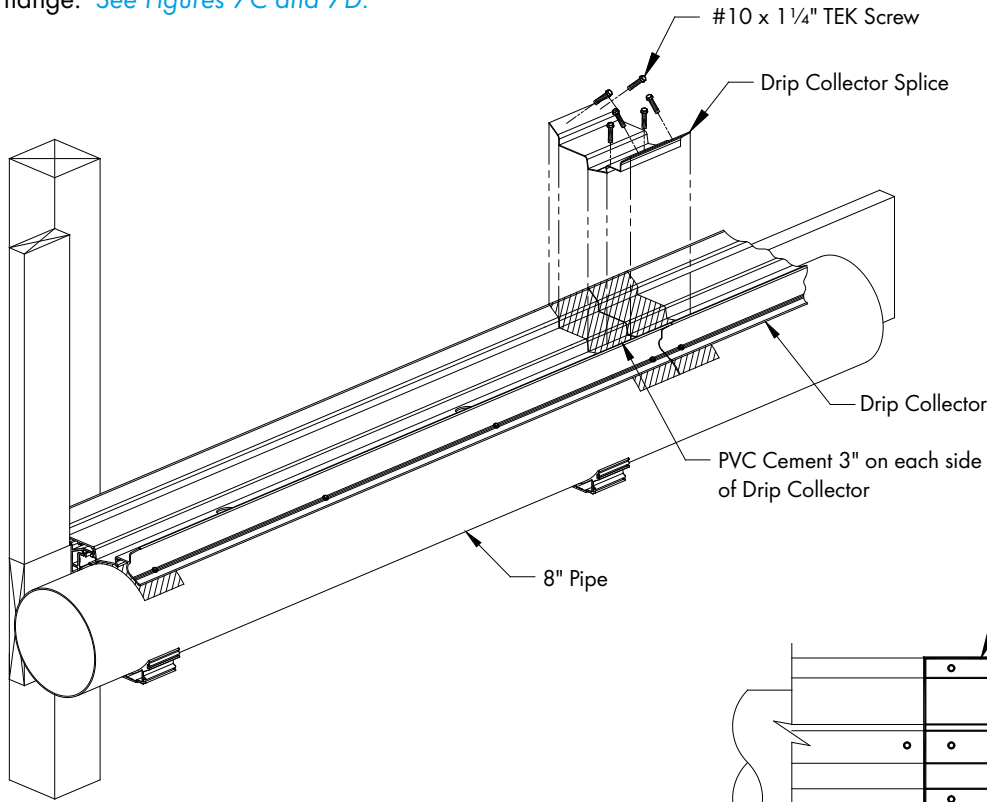

Figure 7C

Refer to Step 14 for caulking procedures.

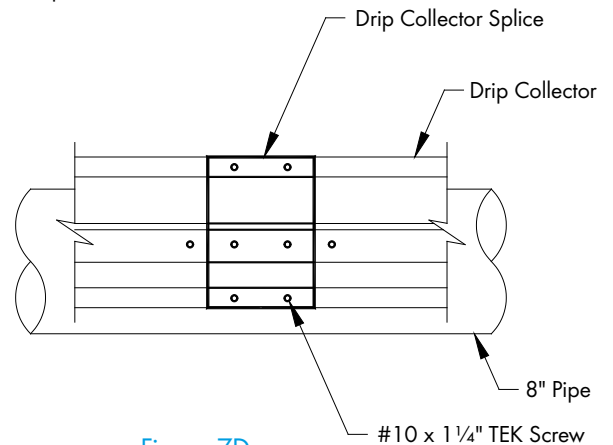

Figure 7D

Step 11

Starting 12" from end of Drip Collector, use a 1 $\frac{3}{8}$ " dia. hole saw and drill a hole through the Drip Collector and 8" Pipe every 24" O.C. Make sure not to leave plugs from drilling hole in the pipe. PVC cement Drain Fitting, into hole. See Figures 8A and 8B.

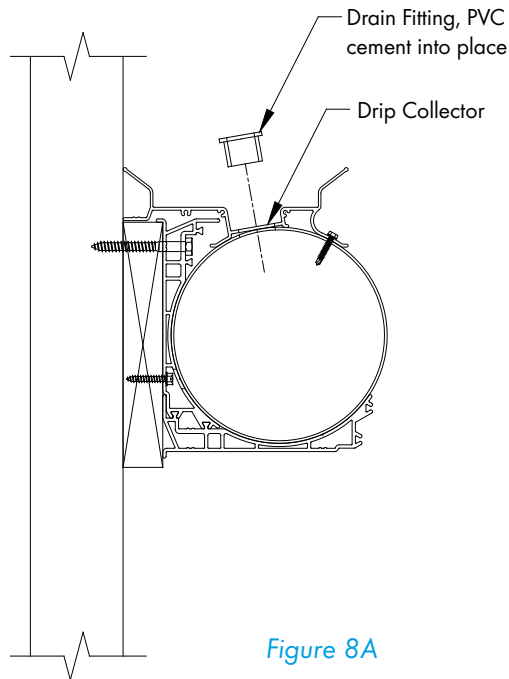

Figure 8A

WARNING

Remove all shavings from inside the pipe and from the top of Drip Collector.

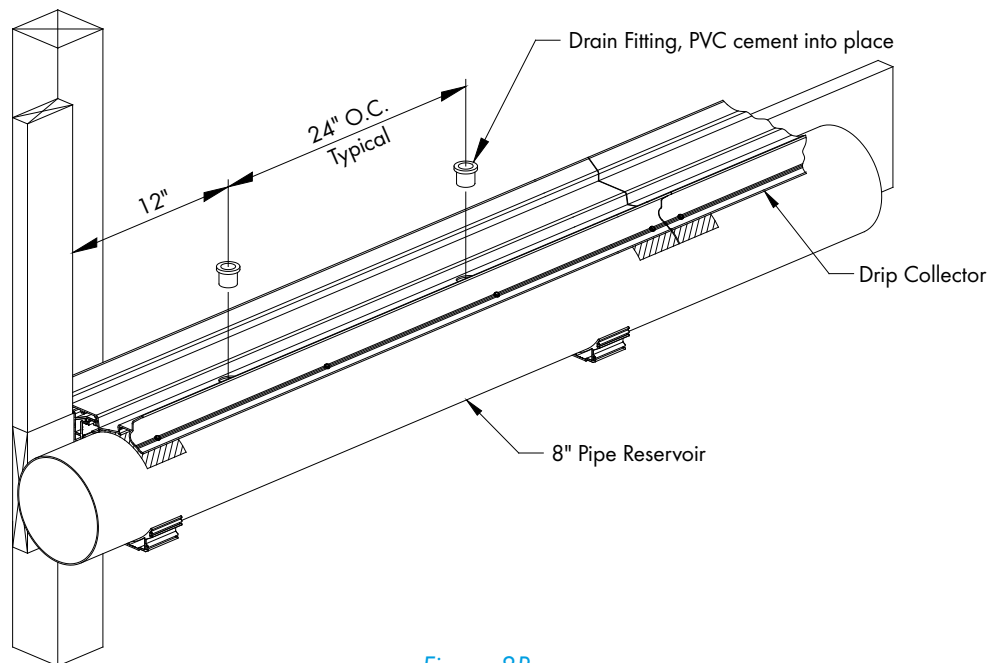

Figure 8B

For Black Poly Tank proceed to Step 12A. For White Pipe Tank proceed to Step 13A.

Black Poly Tank:

Step 12A

Prepare the Black Poly Tank for attachment to the 8" Pipe by removing the flat interior surface of the 8" pipe area, cut the flat end leaving a minimum of 1/4" lip around the edge, *See Figure 9A*. **DO NOT CUT** the outer surface of the 8" pipe area, cutting the round surface will weaken the tank structure. *See Figure 9A*.

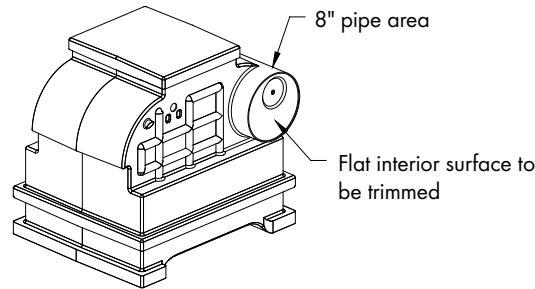
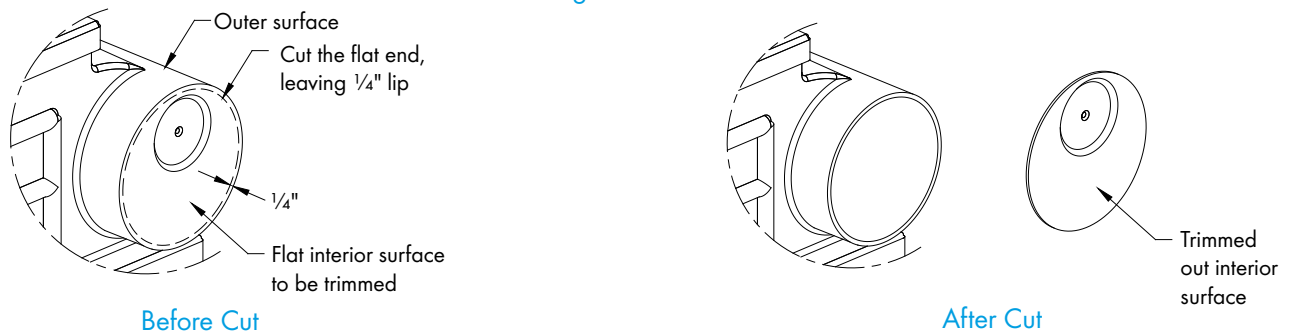

Figure 9A



Step 12B

Slide the Rubber Bellow Connector over the 8" Pipe and the other end over the Black Poly Tank. Be sure the Drip Collector remains on top of the 8" Pipe. Secure in place with Hose Clamps positioned in the grooves of the Rubber Bellow Connector. Install the 8" Rubber Cap on the 8" Pipe end opposite the tank.

See Figures 9B, 9C and 9D.

NOTE: In some installations it may be necessary to bury or elevate the Black Poly Tank for proper alignments with the 8" Pipe; in either case the ground or other support must be capable of supporting 300 lbs. If using the optional 'EC1630, Cooling Tank Drain Kit-below grade' install at this time following the instructions provided with the kit.

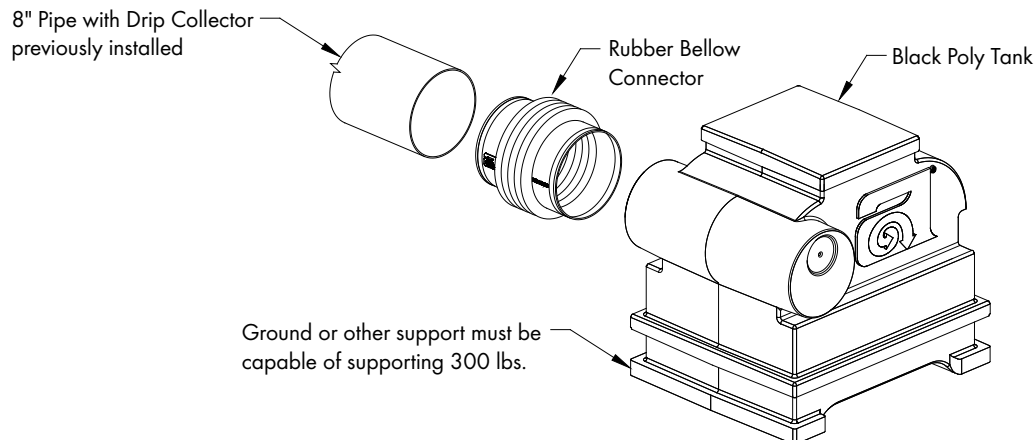

Figure 9B

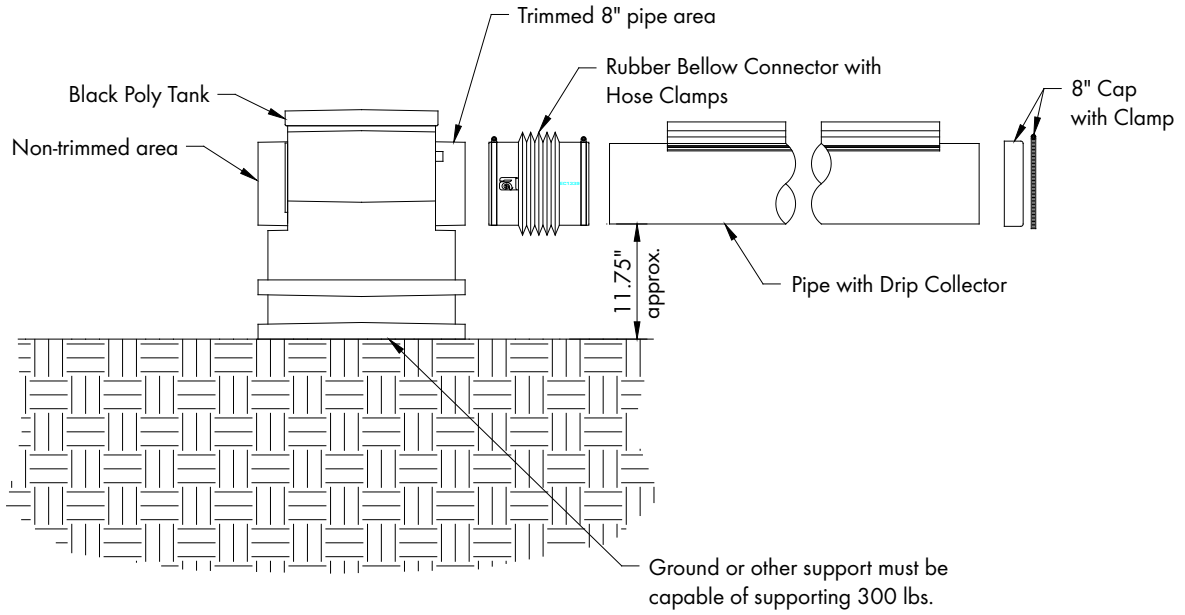

Figure 9C
TANK ON GROUND

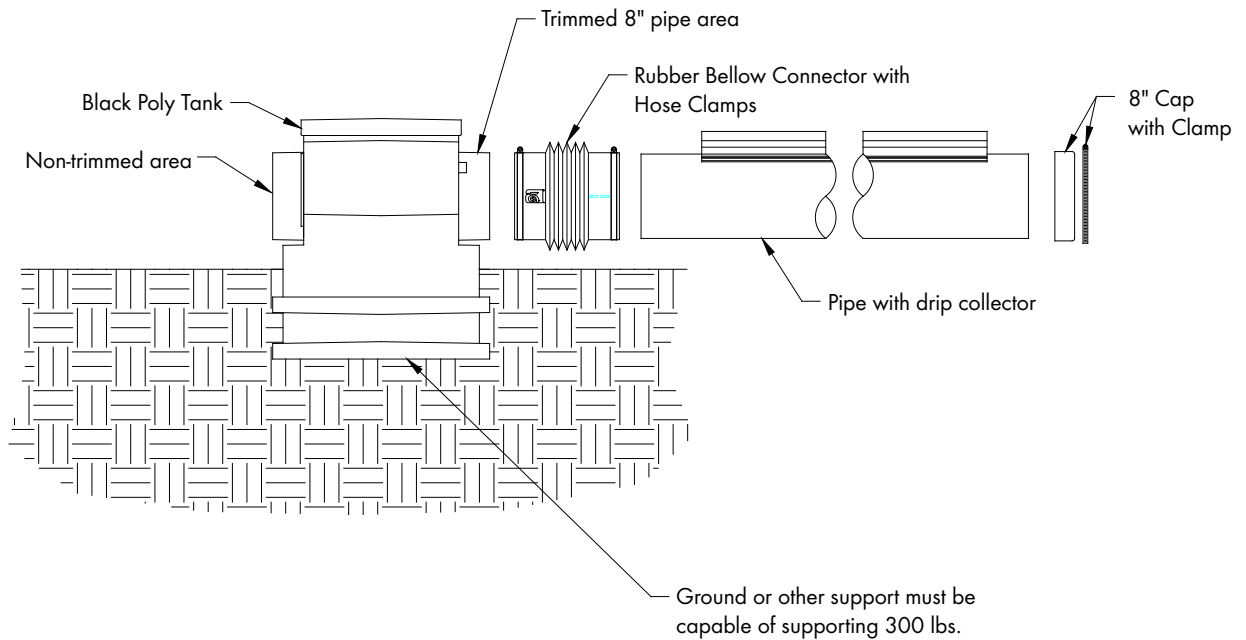

Figure 9D
TANK BURIED

White Pipe Tank:

Step 13A

Prepare the Tee, Pipe Nipples and Pipe Cap in accordance to PVC primer and cement directions and assemble the (2) Pipe Nipples, Tee and Pipe Cap. See Figure 10A.

For completed assembly, See Figures 10B and 10C.

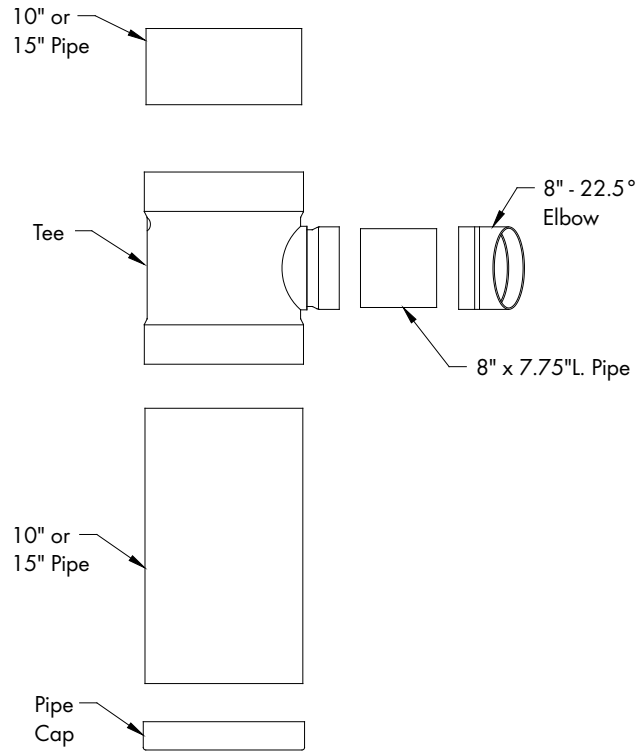

Figure 10A

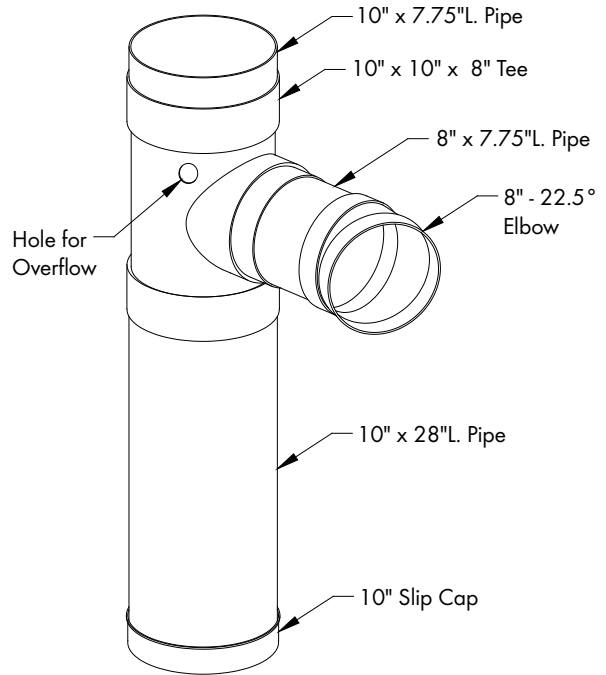

Figure 10B
EC1607, 10" TANK KIT
(COMPLETED)

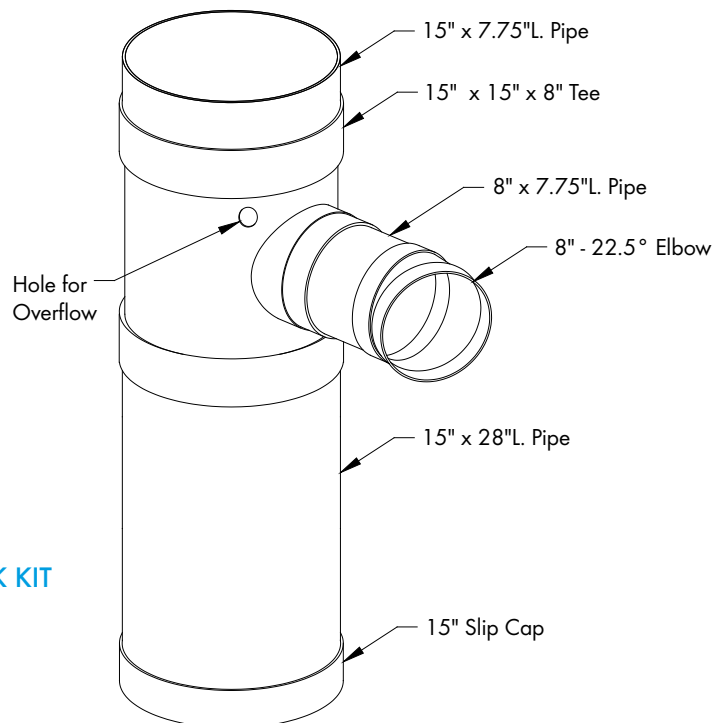

Figure 10C
EC1606 and EC1608, 15" TANK KIT
(COMPLETED)

Step 13B

Once the PVC cement has dried use primer and cement and assemble the tee fully onto pipe. Be sure the Drip Collectors remain on top and the Tee is straight up and down. When Tee is completely installed the 28" L. Pipe Nipple with Cap may need to be buried so that when together, it rests on the ground or another support. See Figures 10D and 10E. Install 8" Cap on end of pipe opposite tee.

NOTE: If using the optional cooling tank drain kit-below grade (EC1630), install at this time following the instructions provided with the kit.

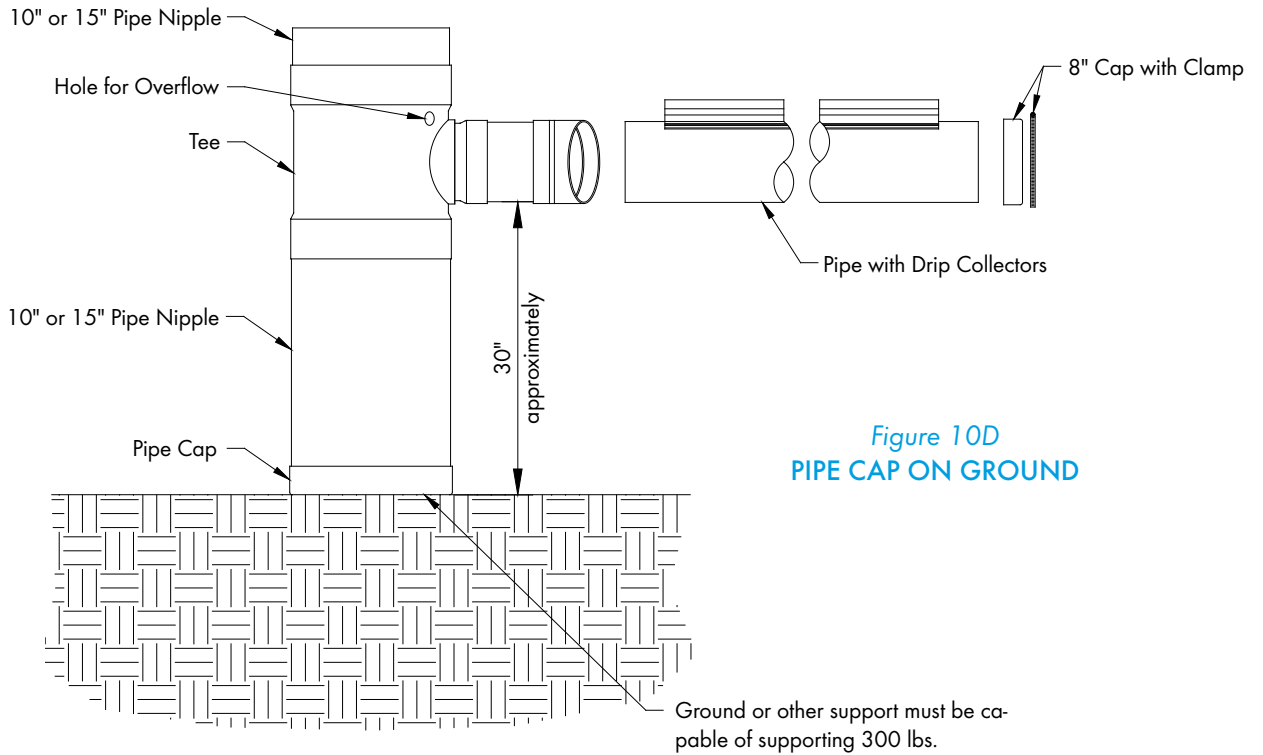

Figure 10D
PIPE CAP ON GROUND

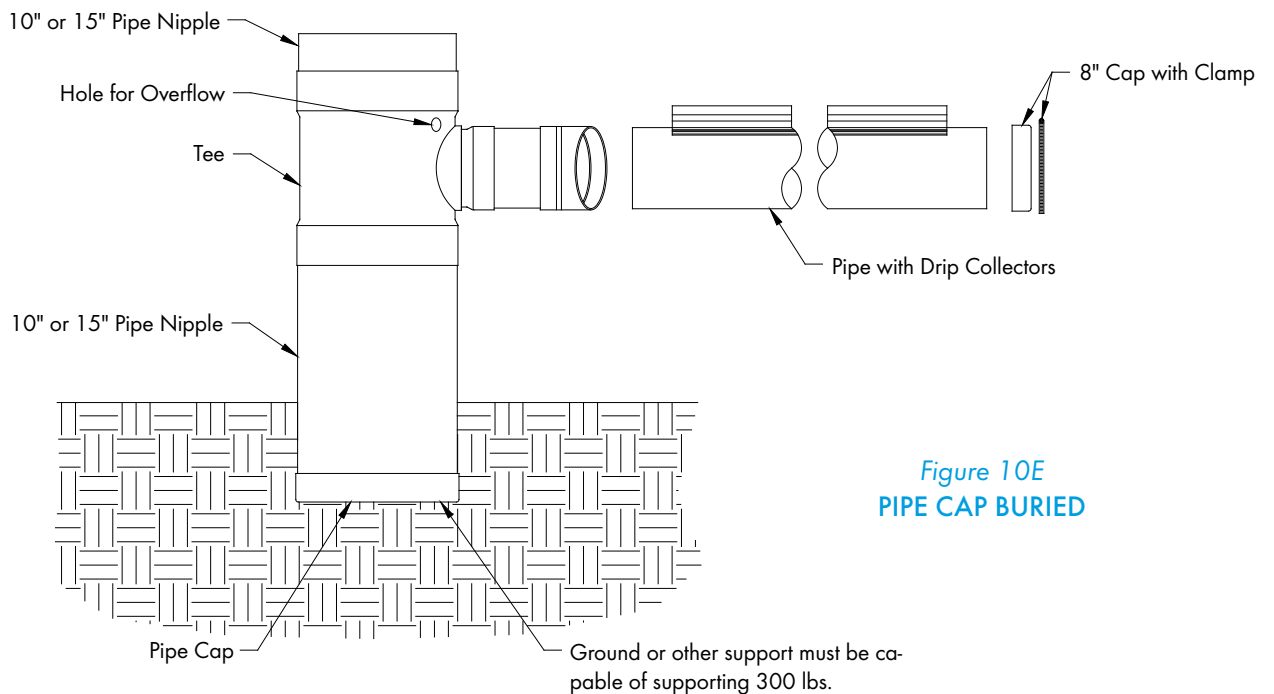

Figure 10E
PIPE CAP BURIED

NOTE: If a 'CH' height extension kit was ordered refer to step 2, page 4 in QM1135.

Step 14A

Determine the height of your cooling system and cut the End Panels down to the correct length according to **Chart B**. Trim the End Panels as indicated below. Determine which End Panel will be at the end with the water supply and drill a 2" - 2¼" dia. hole 1⅞" from top, as shown. If the EC1507 Flush-Out Kit was purchased, then drill a 2" - 2¼" dia. hole in the other End Panel also. See **Figure 11A and 11B**.

Pad Height	Length of End Panel
24"H.	27¼"H.
36"H.	39¼"H.
48"H.	51¼"H.
60"H.	63¼"H.
72"H.	75¼"H.

Chart B

**Figure 11A
LEFT END PANEL**

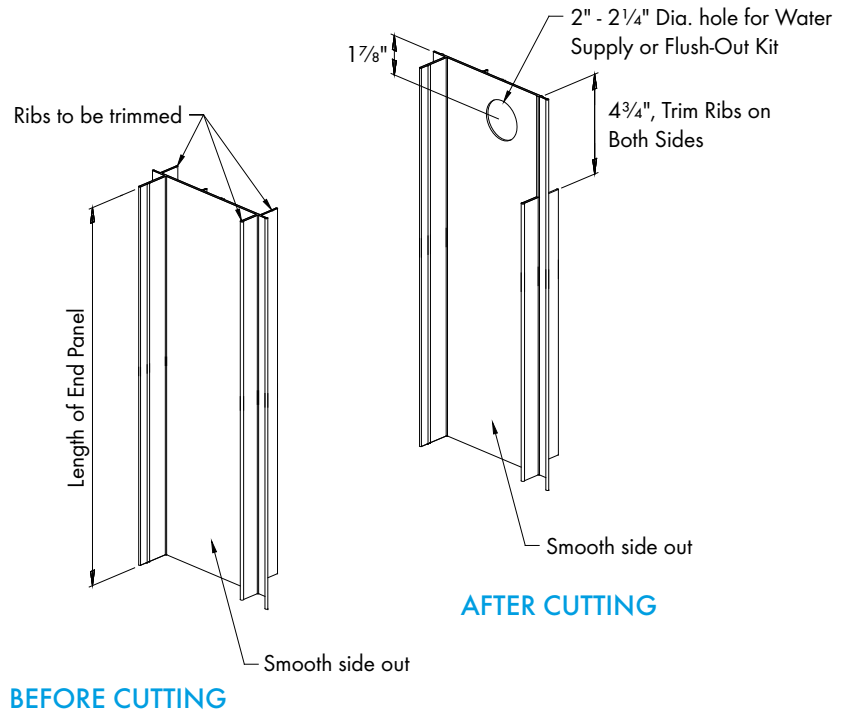

NOTE: Smooth side of end panel is the outside of system (Figure 11A). Grooved side of end panel is facing the pad (Figure 11B).

**Figure 11B
RIGHT END PANEL**

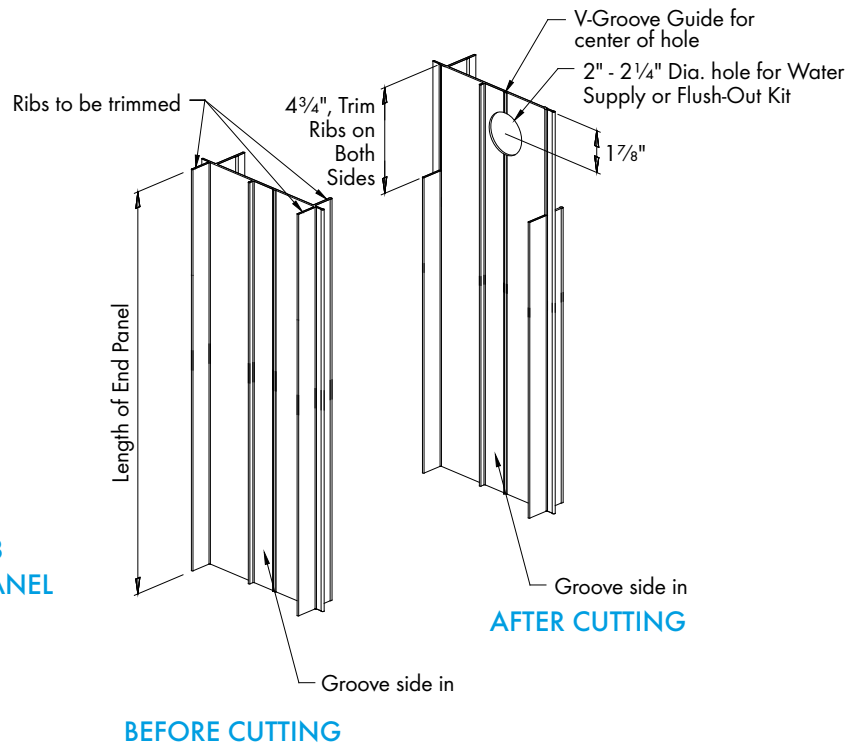

Step 14B

Apply PVC cement to left end of Drip Collector. On left side of system line up the 3 holes in the Drip Collector End Cap to the 'U' Channels in the Drip Collector, fasten using (3) #10 x 1/4" TEK Screws (provided). See Figure 11C.

Step 14C

Slide left End Panel into framing and into Drip Collector on left end. End Panel should fit snug, make sure ribs sit down tight into the Drip Collector. Fasten the Drip Collector End Cap to the End Panel using (2) #10 x 1/4" TEK Screws. See Figure 11E.

Step 14D

Hold the End Panel tightly against the framing and attach End Panel to framing using #10 x 1/4" TEK Screws (provided), See Figure 11D. See Chart C for spacing and number of TEK Screws provided.

Pad Height	No. of Screws	Spacing	Spacing Top to First Screw
24"H.	1	24"O.C.	2"
36"H.	2	18"O.C.	2"
48"H.	2	24"O.C.	2"
60"H.	3	20"O.C.	2"
72"H.	3	24"O.C.	2"

Chart C

WARNING

PVC cement must be completely dried before filling system with water. Failure to do so may result in pipe and tee sections coming apart.

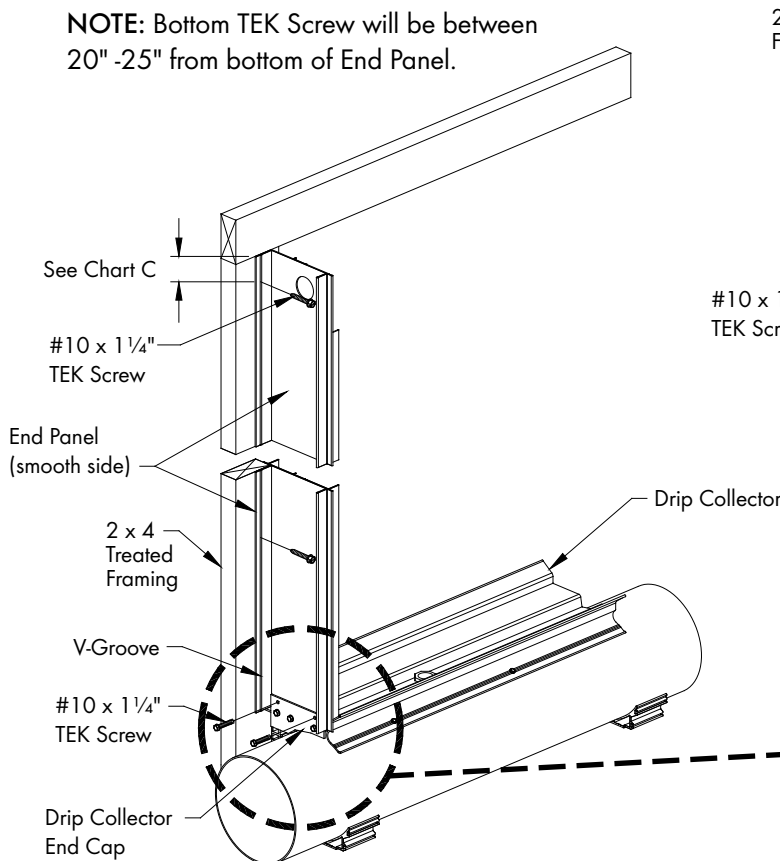

Figure 11D

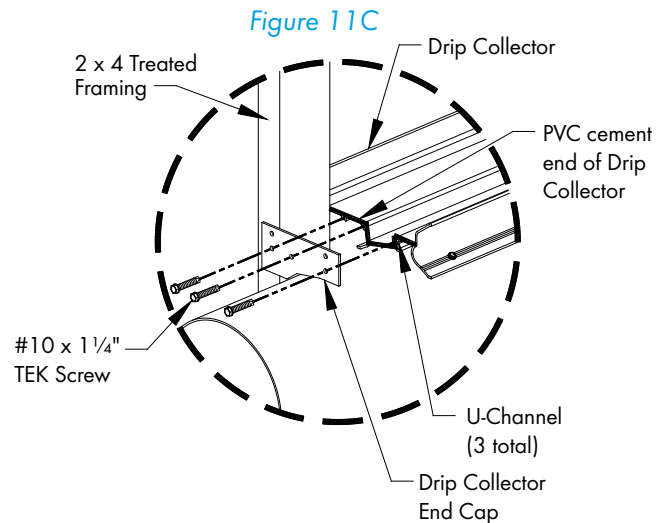

Figure 11C

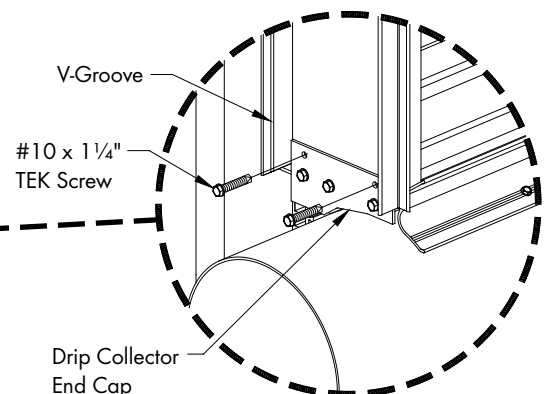

Figure 11E

NOTE: If a 'CH' height extension kit was ordered refer to step 3, page 5 in QM1135.

Step 15A

Using caulk provided, start at left end and caulk inside and outside of End Panel and Drip Collector End Cap where they meet Drip Collector and 8" Pipe. Also caulk the screw head in bottom of Drip Collector and screws coming in thru End Panel. See Figure 12A & 12B.

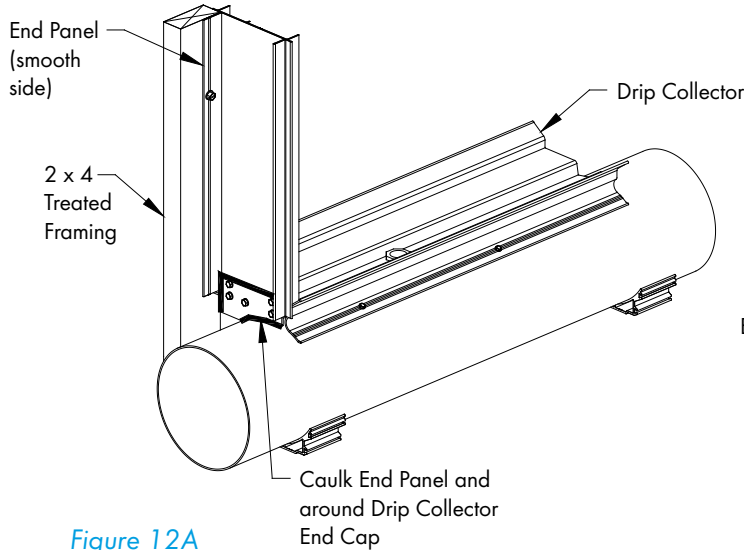

Figure 12A
View from Outside

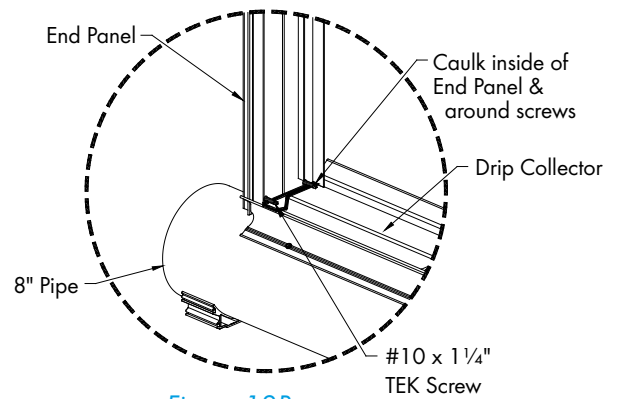

Figure 12B
View from Inside

Step 15B

Working down the length of the cooling, apply a wide bead of caulk at each edge of Drip Collector Splices. Be sure to form caulk around all surfaces and over TEK Screws. Caulk over TEK Screws should be at least 1/4" diameter in size. Apply a bead of caulk around each Drain Fitting in Drip Collector. See Figure 12C.

Step 15C

Refer to Step 19 for further caulking of distribution cap and right end panel.

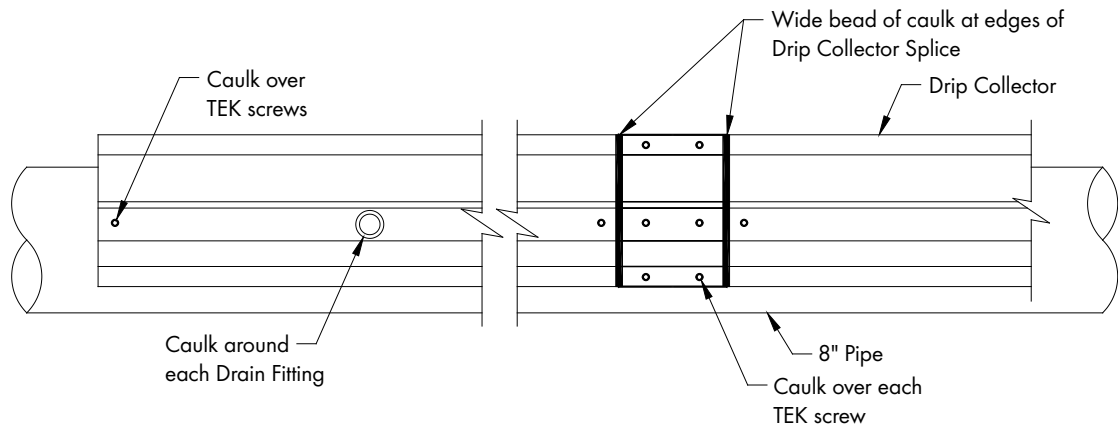

Figure 12C
VIEW FROM ABOVE

Step 16

Slide 6" Stainless Steel Bolts into Distribution Cap and drive into position using hammer and punch. Bolts must be completely seated in. [See Figure 13A.](#)

Step 17

Attach Distribution Cap to left end of framed opening using #14 x 1½" Lag Screws. Be sure to hold Distribution Cap tight against framing and that the Lag Screws go in square so as not to tip Cap upward. [See Figures 13B and 13C.](#) Repeat [Steps 15 and 16](#), leaving a ¼" gap between sections, until you have installed all Distribution Caps.

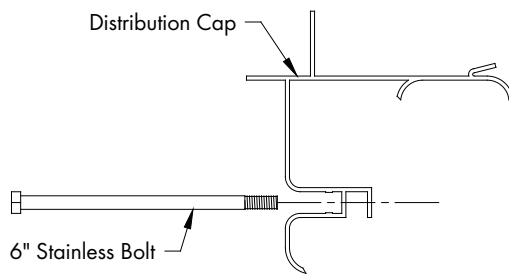

Figure 13A

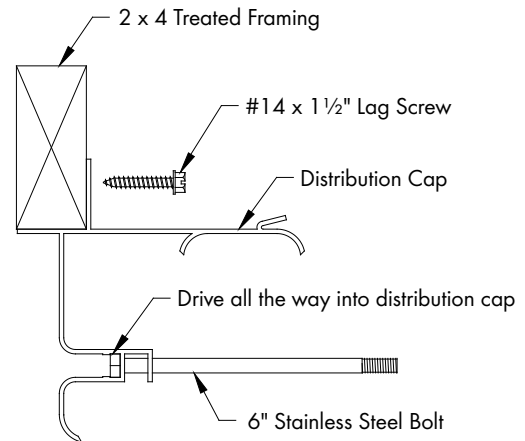

Figure 13B

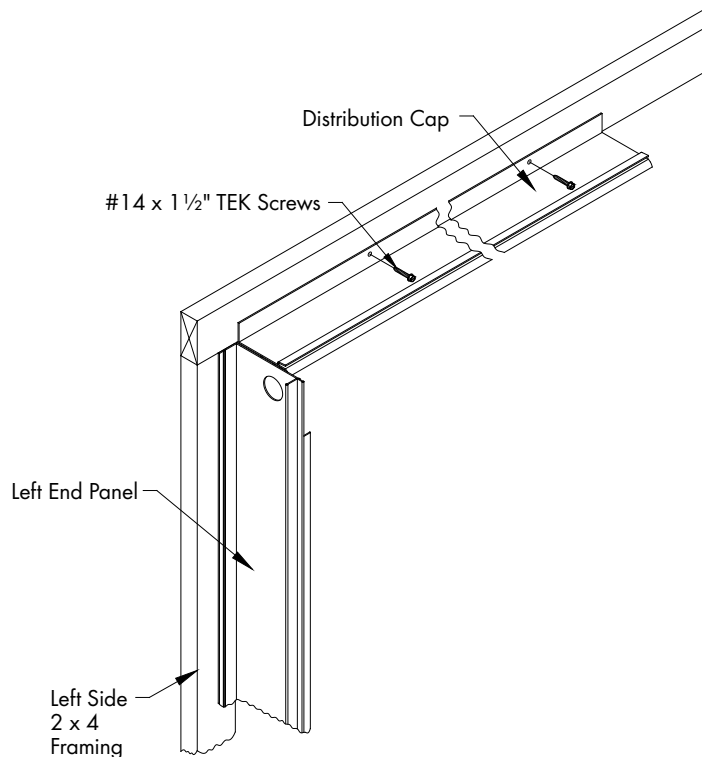

Figure 13C

NOTE: If a 'CH' height extension kit was ordered refer to step 6A, page 7 in QM1135.

Step 18A

On right side of system apply PVC cement to end of Drip Collector and line up the 3 holes in the Drip Collector End Cap to the 'U' Channels in the Drip Collector, fasten using (3) #10 x 1 1/4" TEK Screws (provided). See Figure 13D.

Step 18B

Slide right End Panel into framing and into Drip Collector on right end. End Panel should fit snug, make sure ribs sit down tight into the Drip Collector. Fasten the last 2 screws into the Drip Collector End Cap using (2) 10 x 1 1/4" TEK Screws. See Figure 13D.

Step 18C

Hold the End Panel tightly against the framing and attach End Panel to framing using #10 x 1 1/4" TEK Screws (provided), See Figure 13E. See Chart C, page 15 for spacing and number of Lag screws provided.

Step 19

Apply a bead of caulk at each joint in Distribution Cap and caulk around inside and outside of End Panel and Drip Collector End Cap where the End Panel meets the Drip Collector and 8" Pipe. See Figure 13F. Also caulk the screw head in bottom of Drip Collector and Screws coming in thru End Panel.

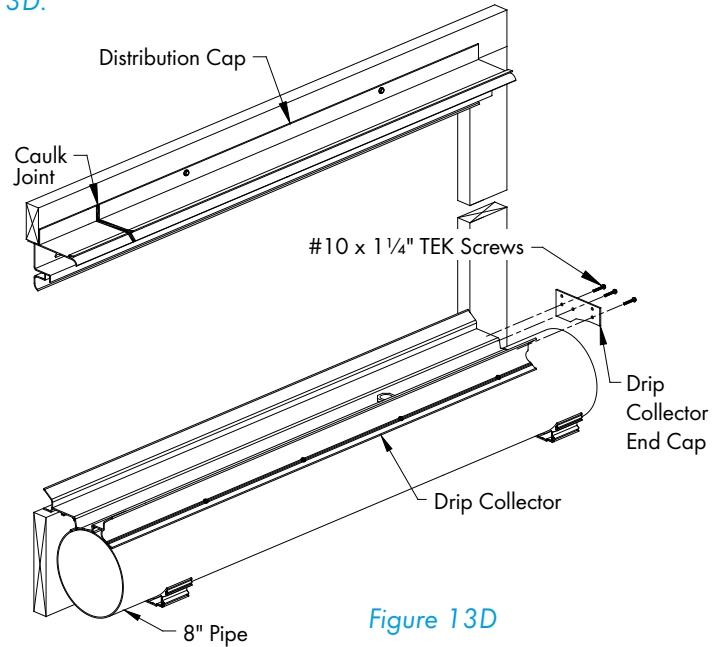

Figure 13D

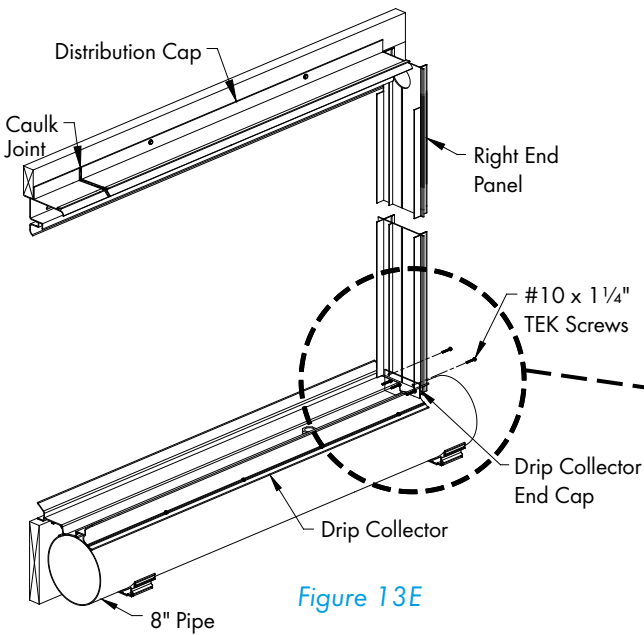

Figure 13E

*****IMPORTANT*****
 Recheck all caulk joints, before proceeding, to insure everything is sealed. Add caulk if necessary.

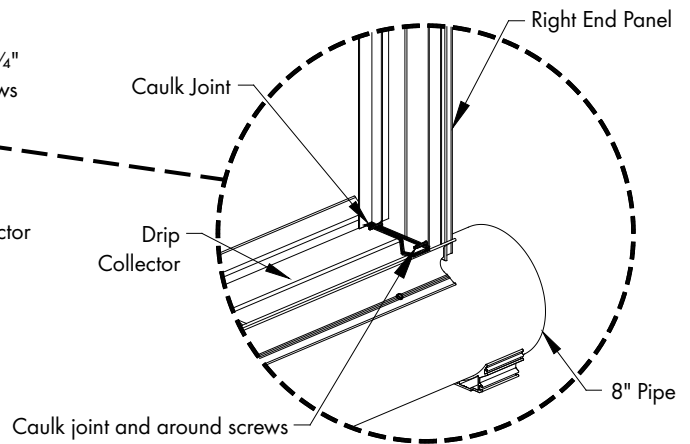

Figure 13F

Step 20

Slide Distribution Pipe Holders over Distribution Pipe, one for every 2' of pipe. See Figure 14A. The section of pipe with the slip cap will go on the end opposite the supply/pump end. For systems longer than 10', connect sections of pipe together keeping holes aligned and fasten together with #10 x 1 1/4" TEK Screw. See Figure 14B. Position pipe and distribution pipe holders in distribution cap on stainless steel bolts. Rotate pipe so that holes are straight upward (12 o'clock). See Figure 14C.

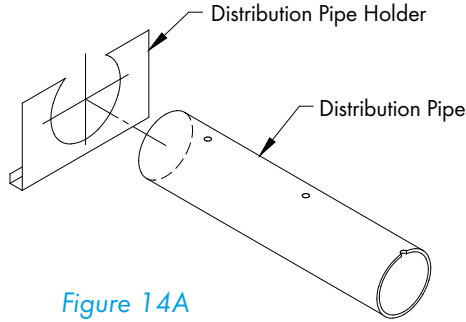

Figure 14A

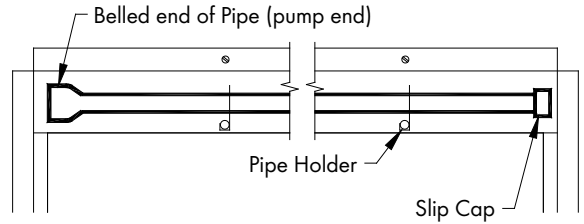

Figure 14B

NOTE: If a 'CH' height extension kit was ordered refer to step 9, page 8 in QM1135.

Step 21

Make sure caulk is dry and begin putting Cooling Pad in place, taking care to position pieces tight together. If your pad has Directional Arrows, position arrows to point upward and to the inside of the building. See Figure 15. Continue this pattern, stopping at the next to the last piece of Pad.

Step 22

Slide the next to the last piece of Pad into the End Panel. Measure the opening that is left for the last piece of Pad at the top and bottom of the opening. If the opening is smaller than the width of the last piece of Pad, then using a hand saw, trim the last piece of Cooling Pad to fit the opening. Put the last piece in place. See Figure 16.

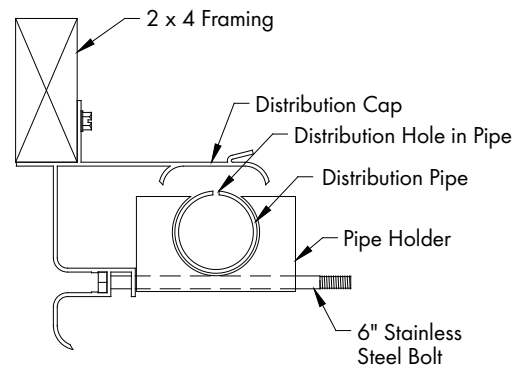

Figure 14C

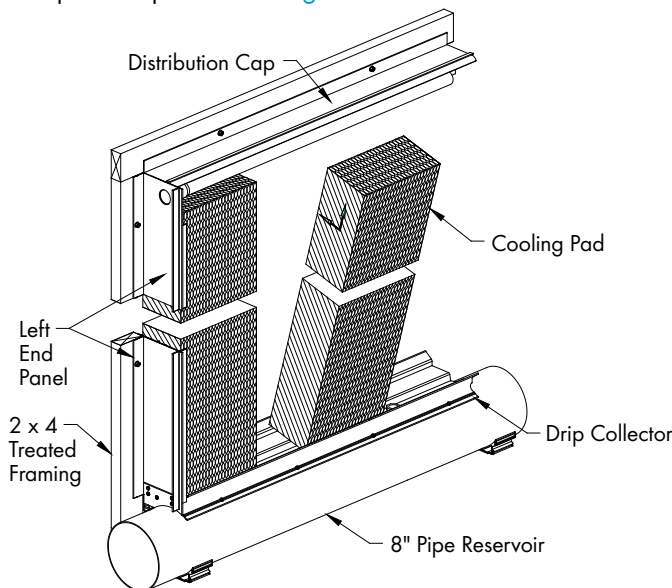

Figure 15

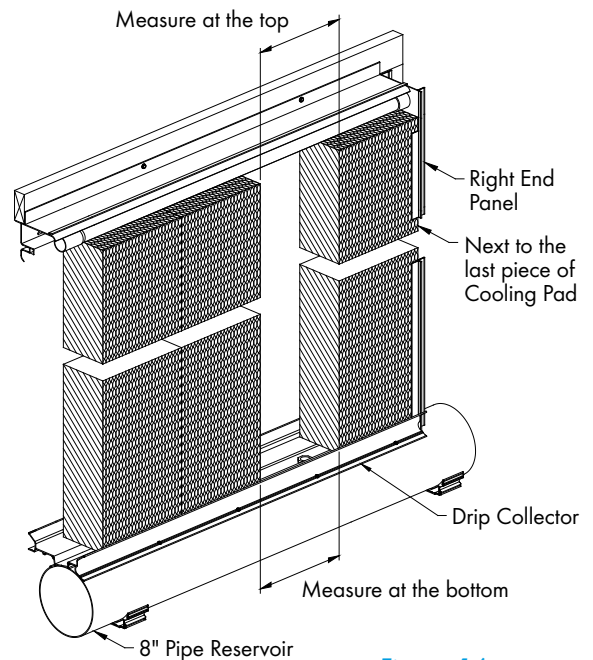

Figure 16

Step 23

Slide 10"L. pipe nipple through hole in end panel nearest the pump and fit it into the belled end of the distribution pipe. Make sure that the holes in the distribution pipe are pointing straight up.

Step 24

For **Standard Pad Retainer**: Slide Pad Retainer section(s) onto Stainless Steel Bolts. Lift Pad Retainer up and slide into groove on Distribution Cap and hold in place while tightening Nylon Wing Nuts. *See Figure 17A.*
 For **Open Header Pad Retainer**: Slide pad retainer onto Stainless Steel Bolts and fasten in place with Nylon Wing Nuts. *See Figure 17B.*

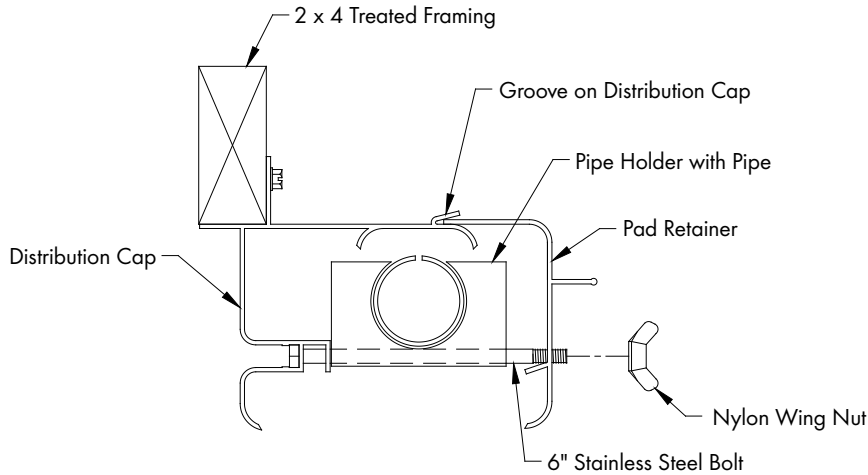

Figure 17A
Standard Pad Retainer

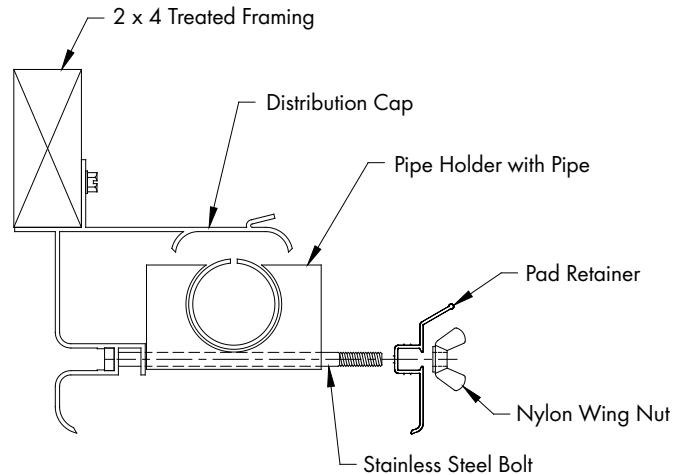

Figure 17B
Open Header Pad Retainer

Step 25

Holding the left End Panel tight to Distribution Cap, place the long side of the Angle Bracket on the Pad Retainer and the short side over End Panel. See Figure 18A and 18B. Attach the Angle Bracket to the Distribution Cap using (2) #10 x 1 1/4" TEK Screws (provided). Repeat for Right End Panel.

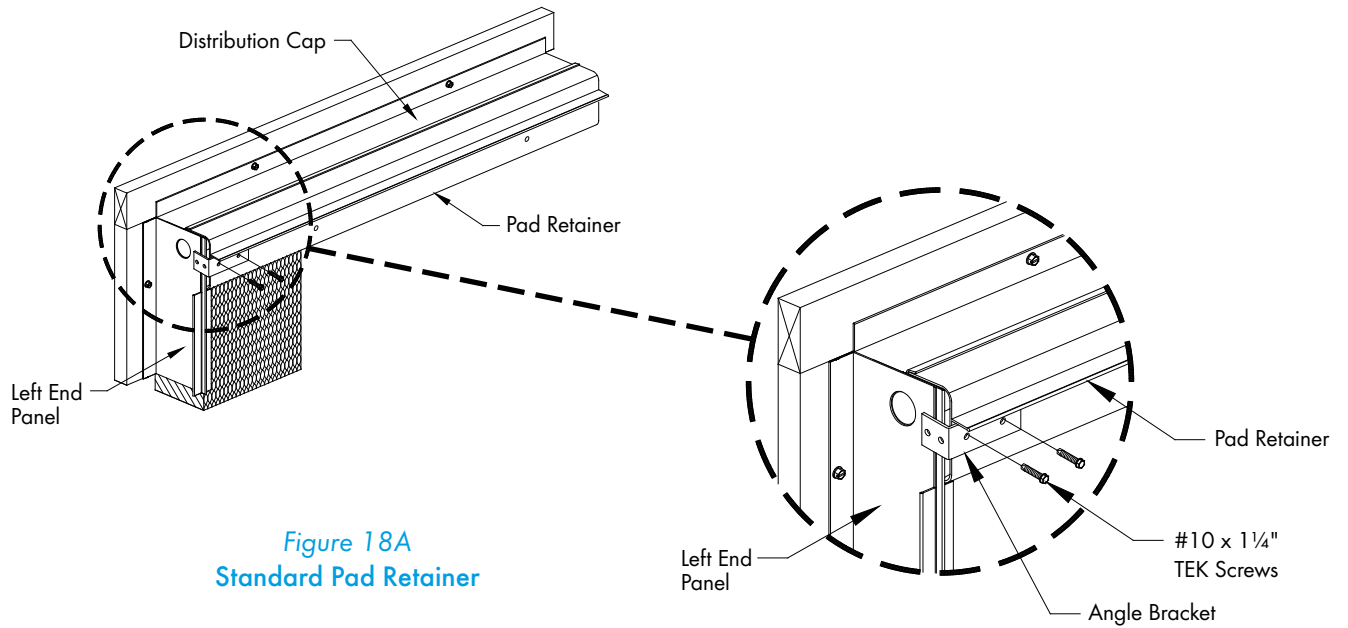

Figure 18A
Standard Pad Retainer

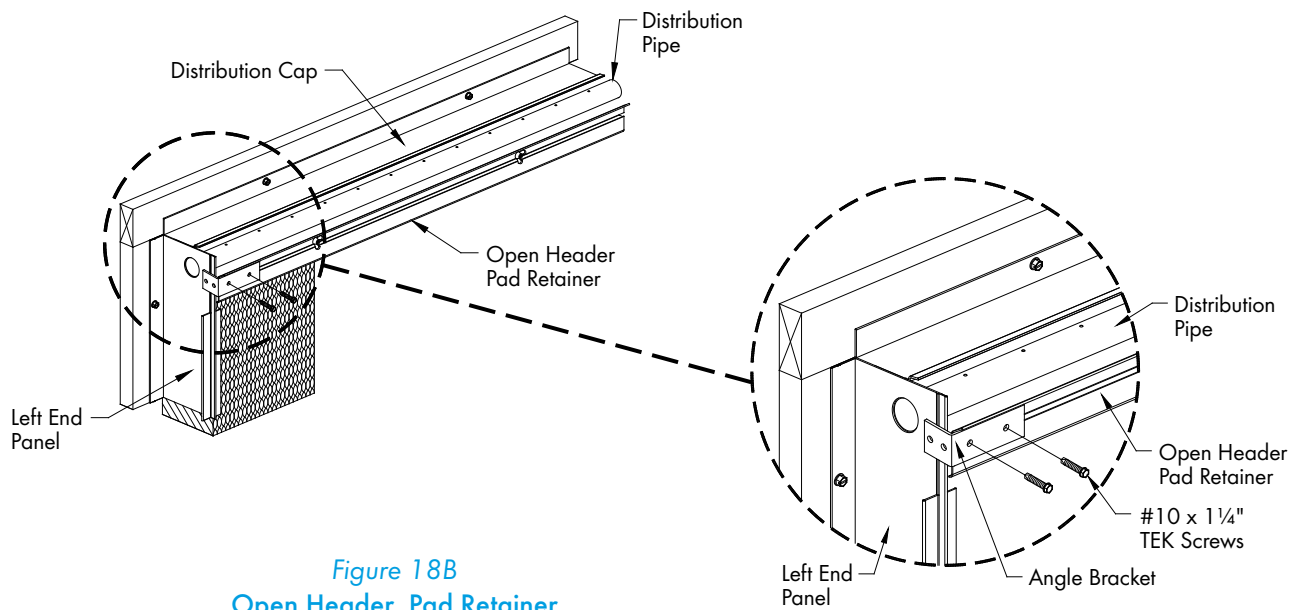

Figure 18B
Open Header Pad Retainer

Step 26

Installation of Cooling Frame is now complete. Installation should resemble that of *Figure 19A and 19B or 19C*. Proceed to next section for plumbing instructions.

NOTE: If a 'CH' height extension kit was ordered refer to step 18, page 13 in QM1135.

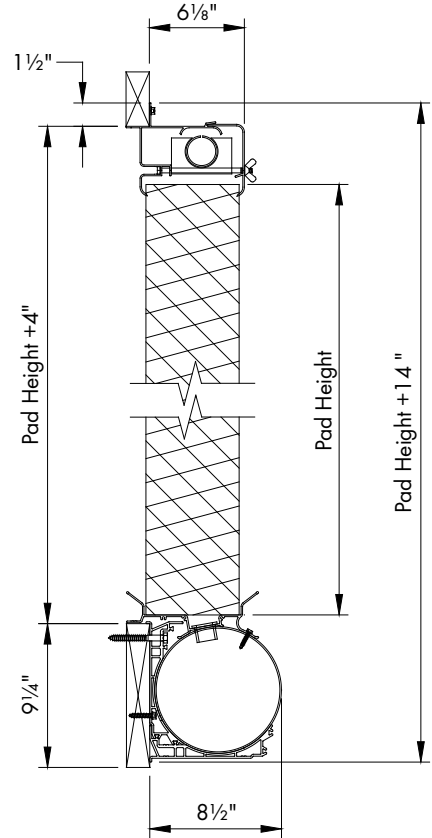
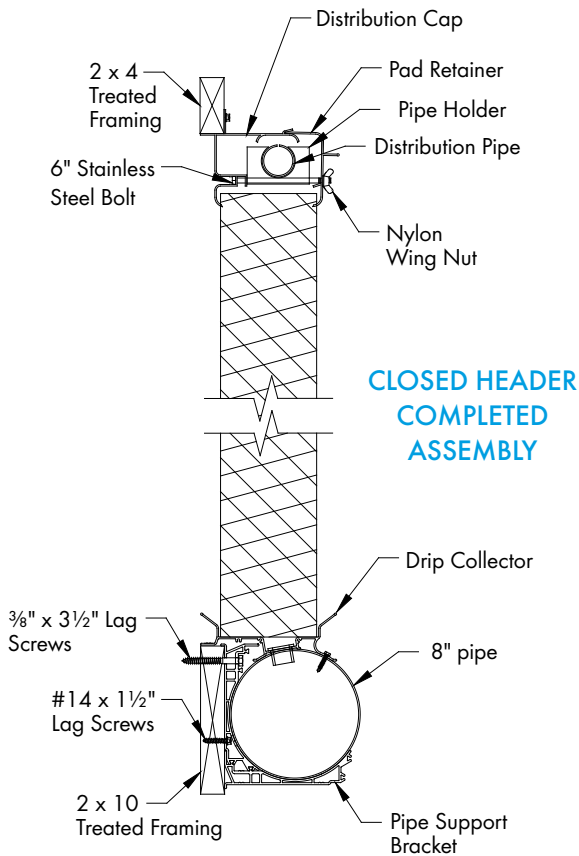
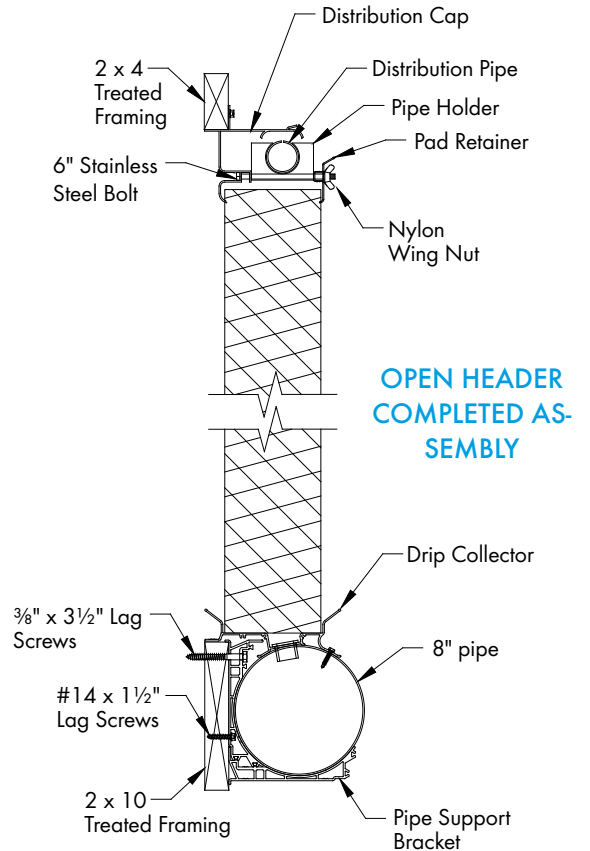

Figure 19A
SIDE VIEW
COMPLETED ASSEMBLY



CLOSED HEADER
COMPLETED
ASSEMBLY



OPEN HEADER
COMPLETED
ASSEMBLY

Figure 19B & C
SIDE VIEW

Plumbing Installation

3.

3.1 Black Poly Tank

Step 1

Cut overflow spout at an angle as shown in [Figure 20A and 20B](#).

Step 2

Using Mounting Plate as a template, drill two (2) $\frac{9}{32}$ " diameter holes and attach Mounting Plate to Tank using $\frac{1}{4}$ " x $\frac{3}{4}$ " Hex Head Bolts and Flange Nuts (provided). See [Figure 20B and 20C](#).

Step 3

Drill a $1\frac{1}{16}$ " hole for Float Valve through the hole in the Mounting Plate. See [Figure 20C](#).

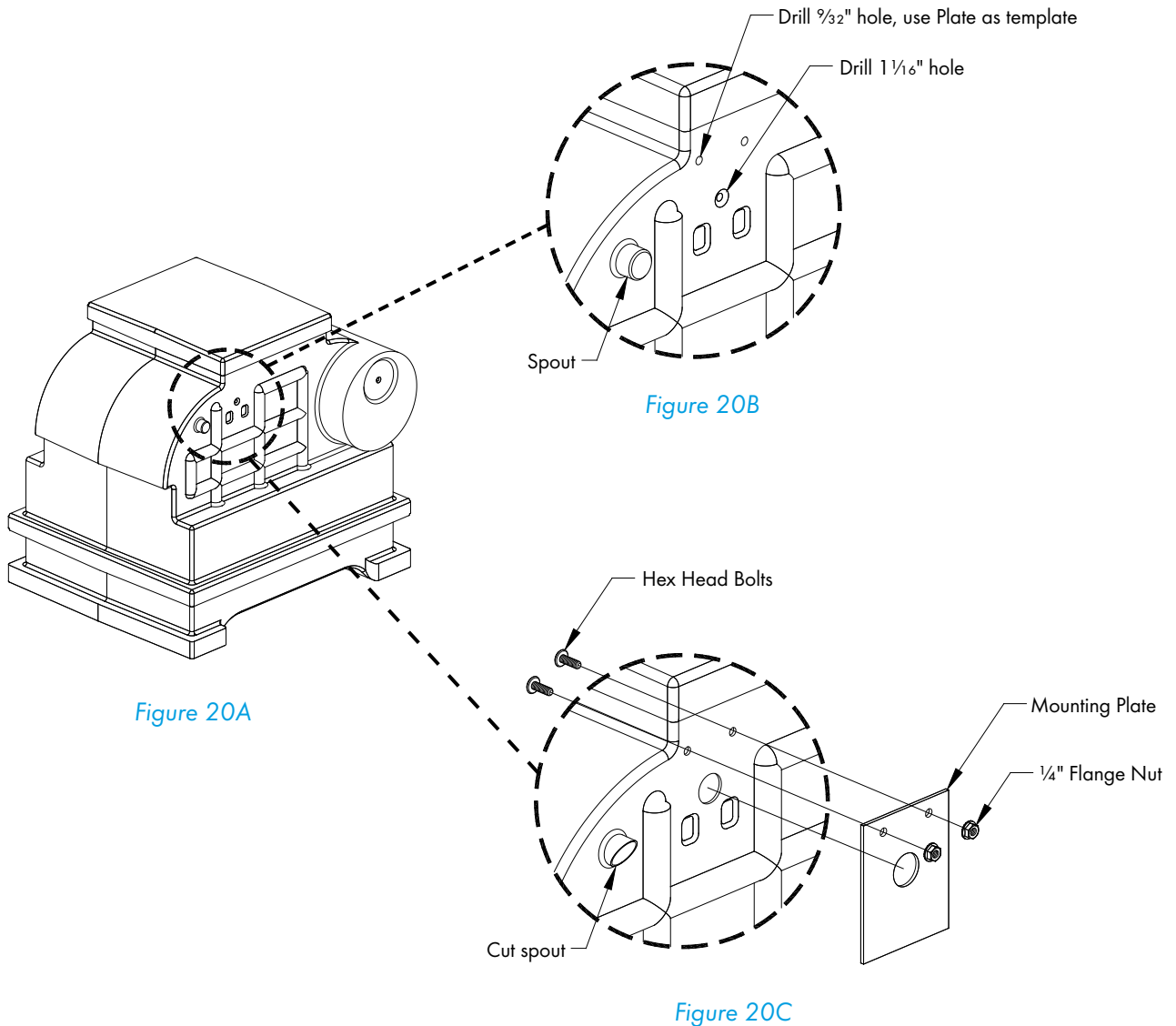

Step 4

Remove Wing Nut and Bolt from Float Assembly and use it to attach the Float Assembly to the Valve Assembly. See Figure 20D.

Step 5

Attach the Float Valve Assembly to the Tank using Washer, Nut and Garden Hose Adapter. See Figure 20E. The Ball of the Float Valve may need some adjustment to attain proper water level in Tank. Proper water level should be approximately 2" below the top of the 8" pipe or level with the opening in the overflow spout.

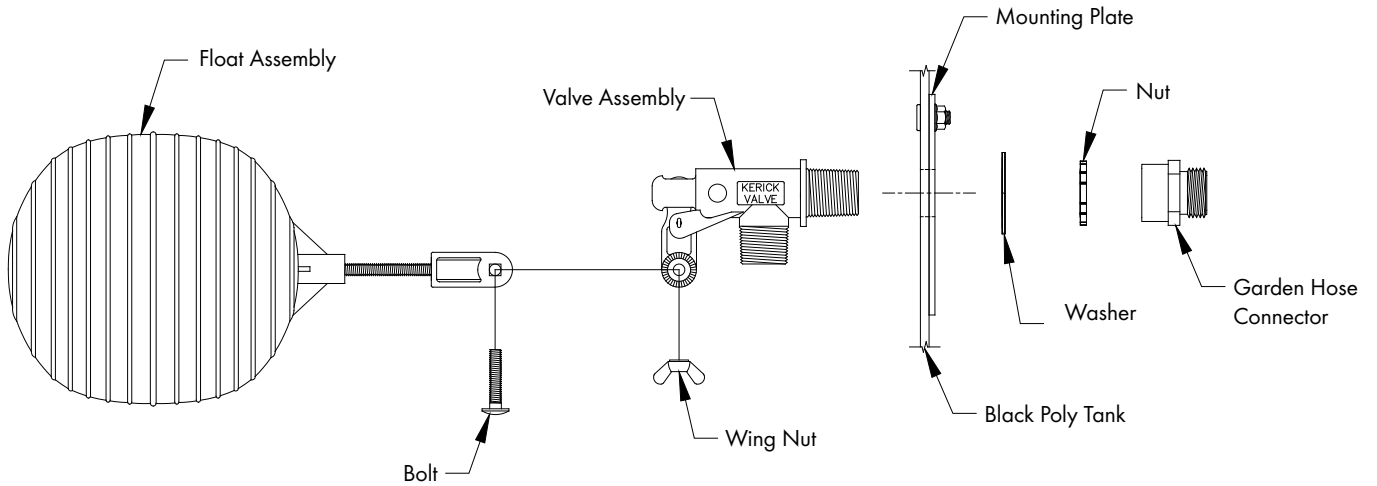

Figure 20D

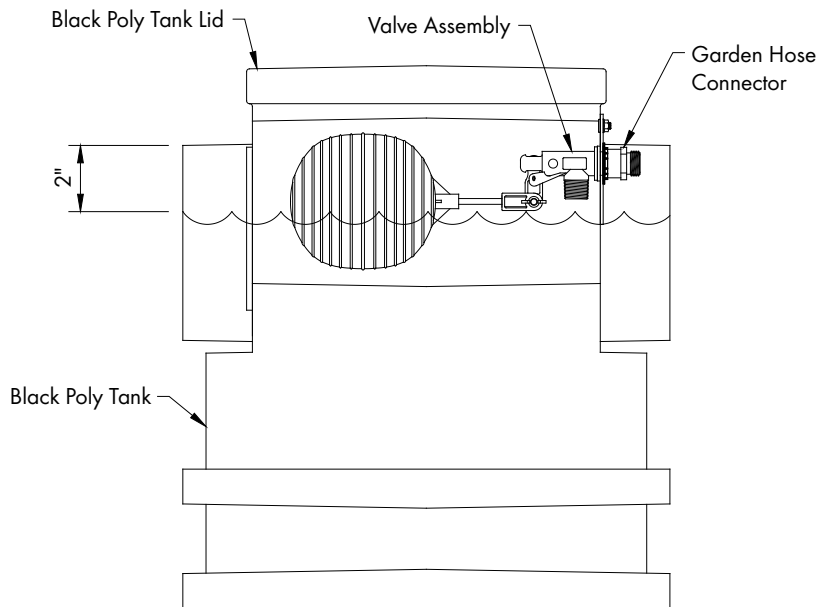

Figure 20E

Step 6

Drill (4) $\frac{3}{16}$ " dia. holes to install snap fasteners using supplied pop rivets at locations shown. See Figure 20F. Place lid on tank before drilling holes. Use snap fasteners for hole pattern.

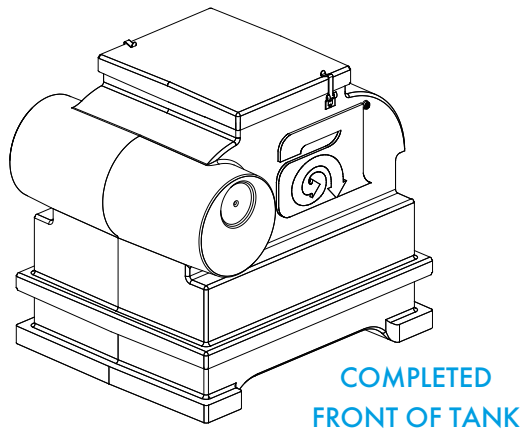
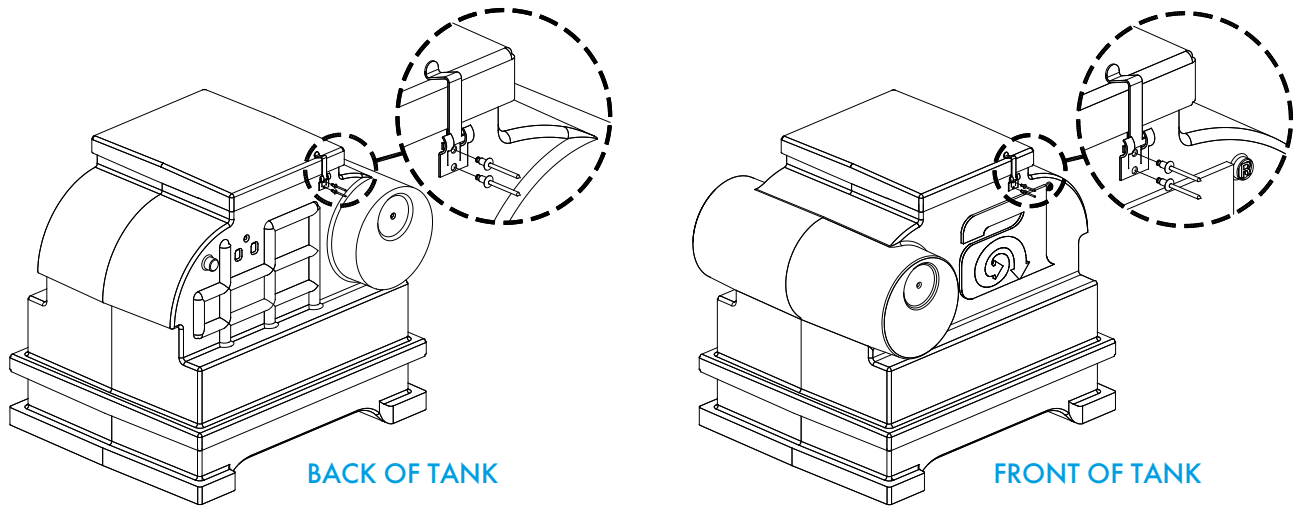

Figure 20F

Step 7

Cut Tank Lid to fit around the $1\frac{1}{2}$ " water supply line connected to the pump. Make the cut match the location of the pump. See Figure 20G.

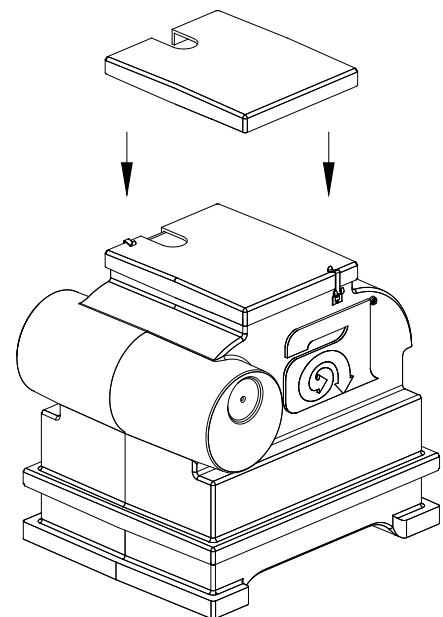

Figure 20G

3.2 White Pipe Tank

Step 8

PVC glue the Drain Fitting and slide into hole in Tee from inside-out. Prime and PVC cement Drain Fitting and 90° Elbow (overflow) and slide Elbow over Drain Fitting, Elbow should turn down. See Figure 21.

Step 9

Remove wing nut and bolt from Float Assembly and use it to attach the Float Assembly to the Valve Assembly. See Figure 22A.

Step 10

Prepare the Float Valve Assembly, Pipe, Coupler and Hose Adapter in accordance to PVC primer and cement directions and assemble the Float Valve Assembly, Pipe, Coupler and Hose Adapter. See Figure 22B.

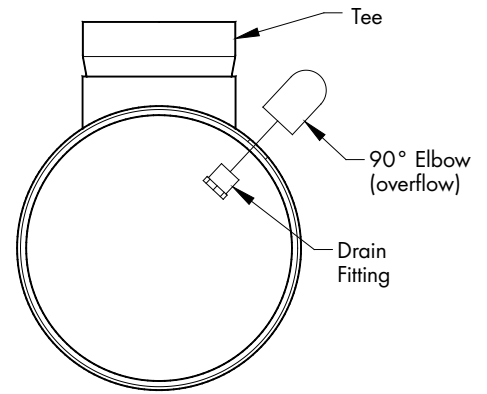
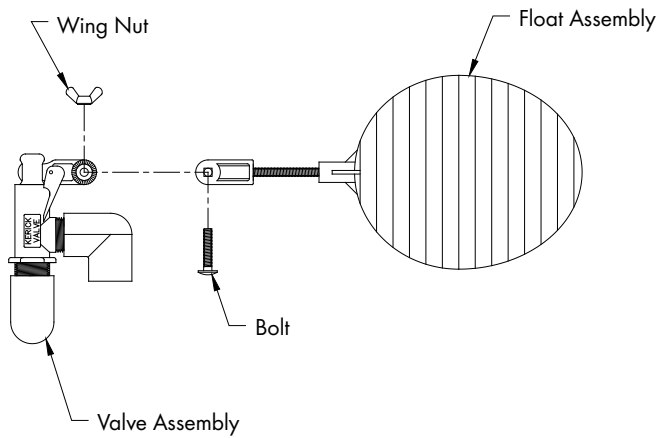
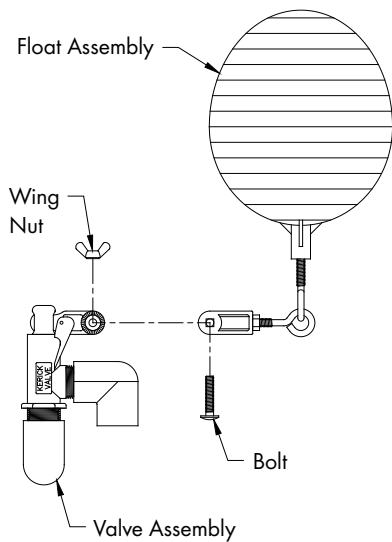

Figure 21



15" TANK



10" TANK

Figure 22A

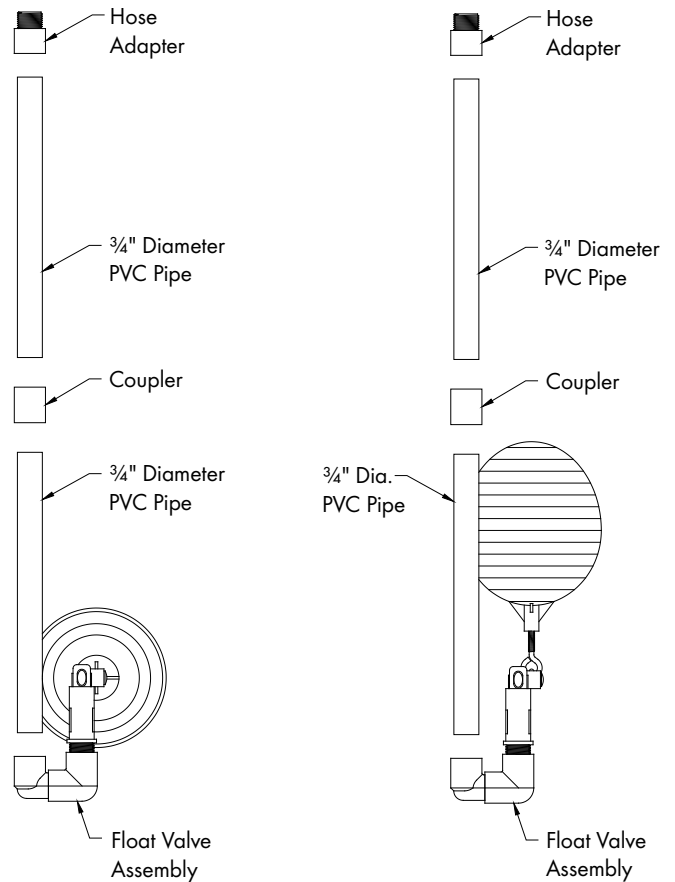

15" TANK

10" TANK

Figure 22B

Step 11

On the cooling system Tank Kit drill (4) 1 1/2" dia. holes as shown in [Figure 22C](#). The holes should be located on the side of the Tank Kit that is opposite the 8" Pipe, and so that the float assembly can swing freely and is not obstructed by anything.

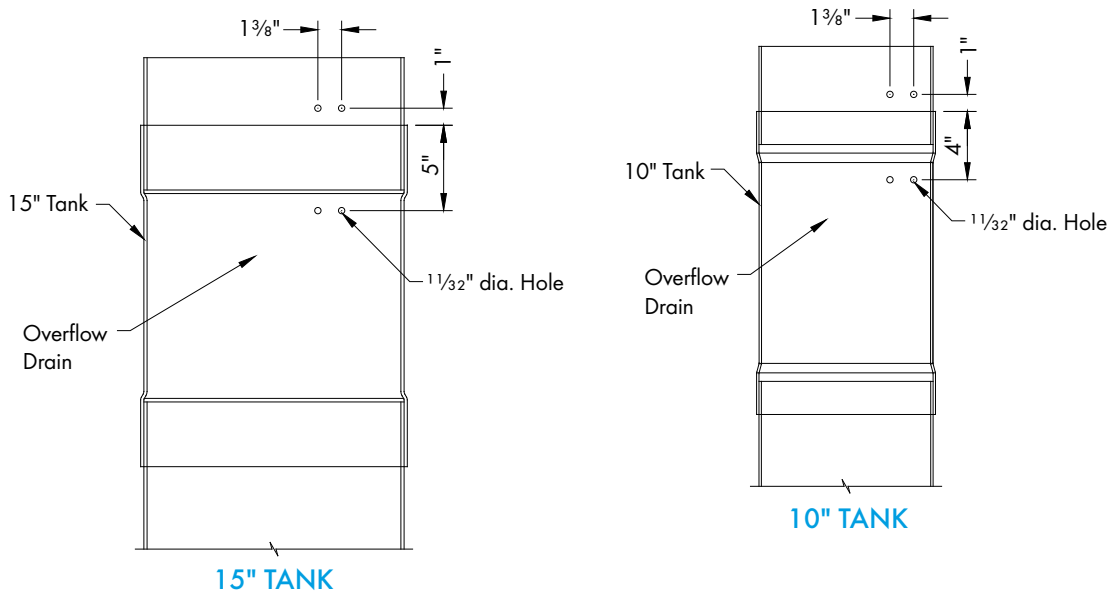

Figure 22C

Step 12

Slide the Float Valve Assembly into the Tank Kit Tee approximately 18 3/4" for the 15" Tank and 25 1/4" for the 10" Tank. Fasten in place using (2) U-bolts and (4) Nylon Wing Nuts. [See Figures 22D and 22E](#).

Position of Float Valve is approximate, some adjustment may be required to attain proper water level in Tank. Proper water level should be approximately 2" below the top of the 8" Pipe. [See Figures 22E](#).

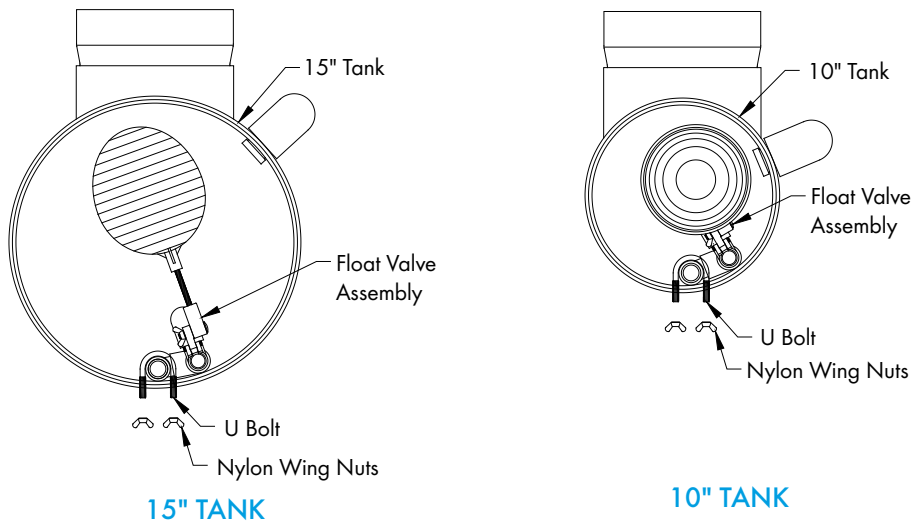

Figure 22D

Step 13

Installation complete. If a higher water level is needed, loosen Wing Nuts and raise Float Assembly and retighten Wing Nuts. If lower level is needed, lower Assembly. See Figure 22E for completed assembly.

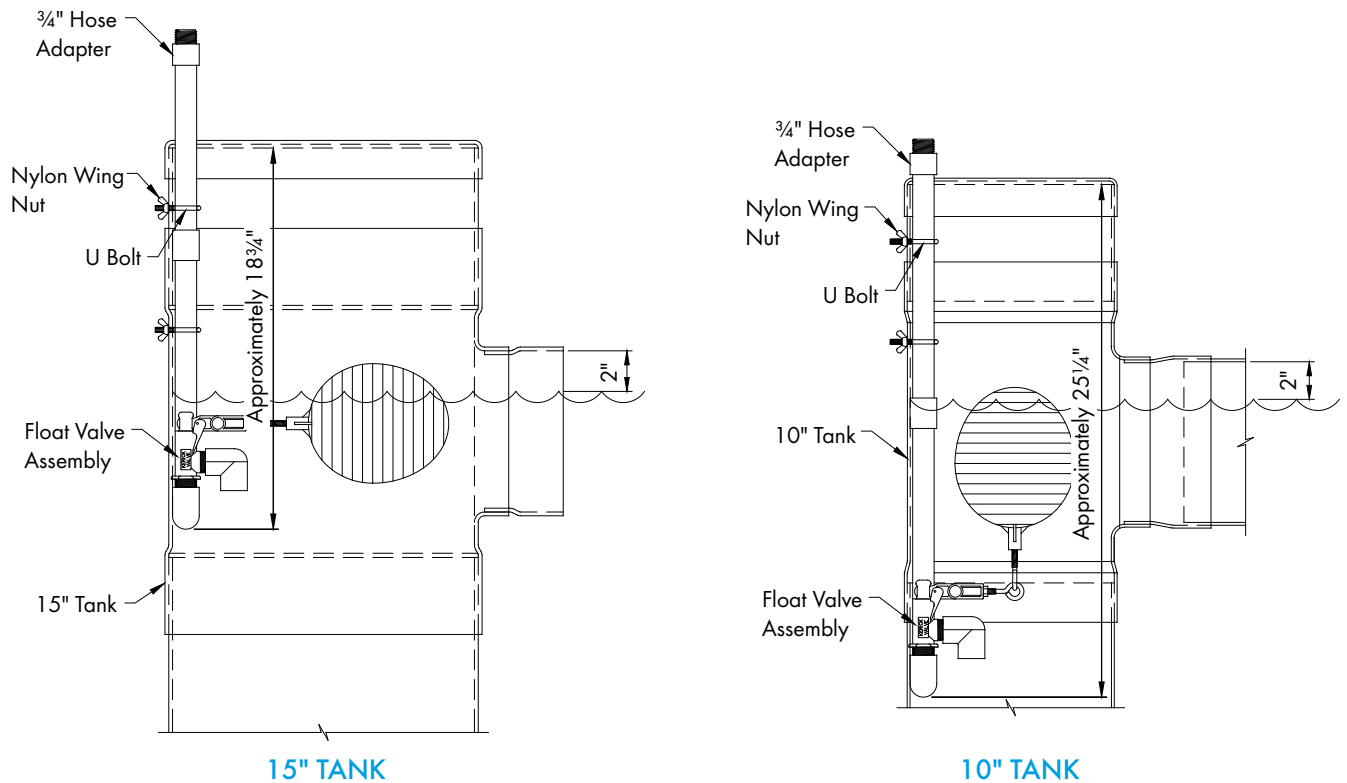

Figure 22E
COMPLETED ASSEMBLY

3.3 Optional Flush-out Kit (EC1507)

Step 1

If Flush-Out Kit (EC1507) was purchased, refer to page 16, Step 14A for instructions on drilling hole in End Panel. Remove the TEK Screw and Pipe Cap from the end of Distribution Pipe. Assemble Flush-Out Kit piping as shown in Figure 23. Installation of the 90° elbow and (1) 1½" x 10" pipe is optional, depending on the desired direction for water flow.

Step 2

Replace Pad Retainer and tighten Wing Nuts. Flush-Out Kit Assembly is now complete.

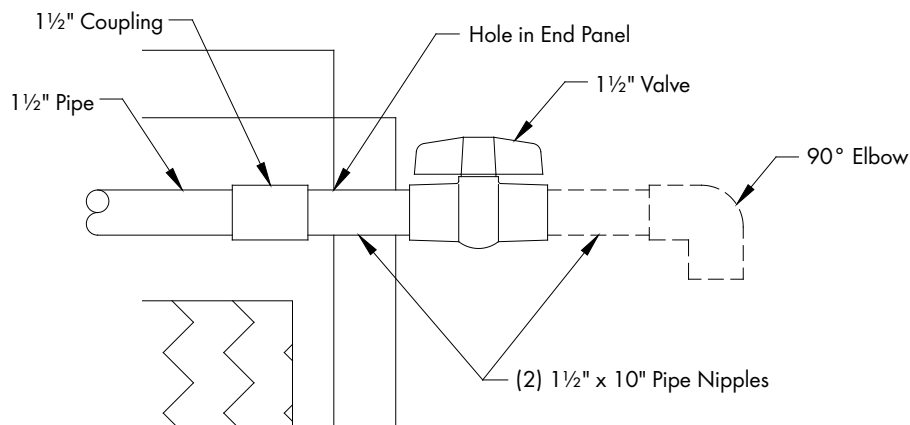

Figure 23

3.4 Cooling System Elevation Views

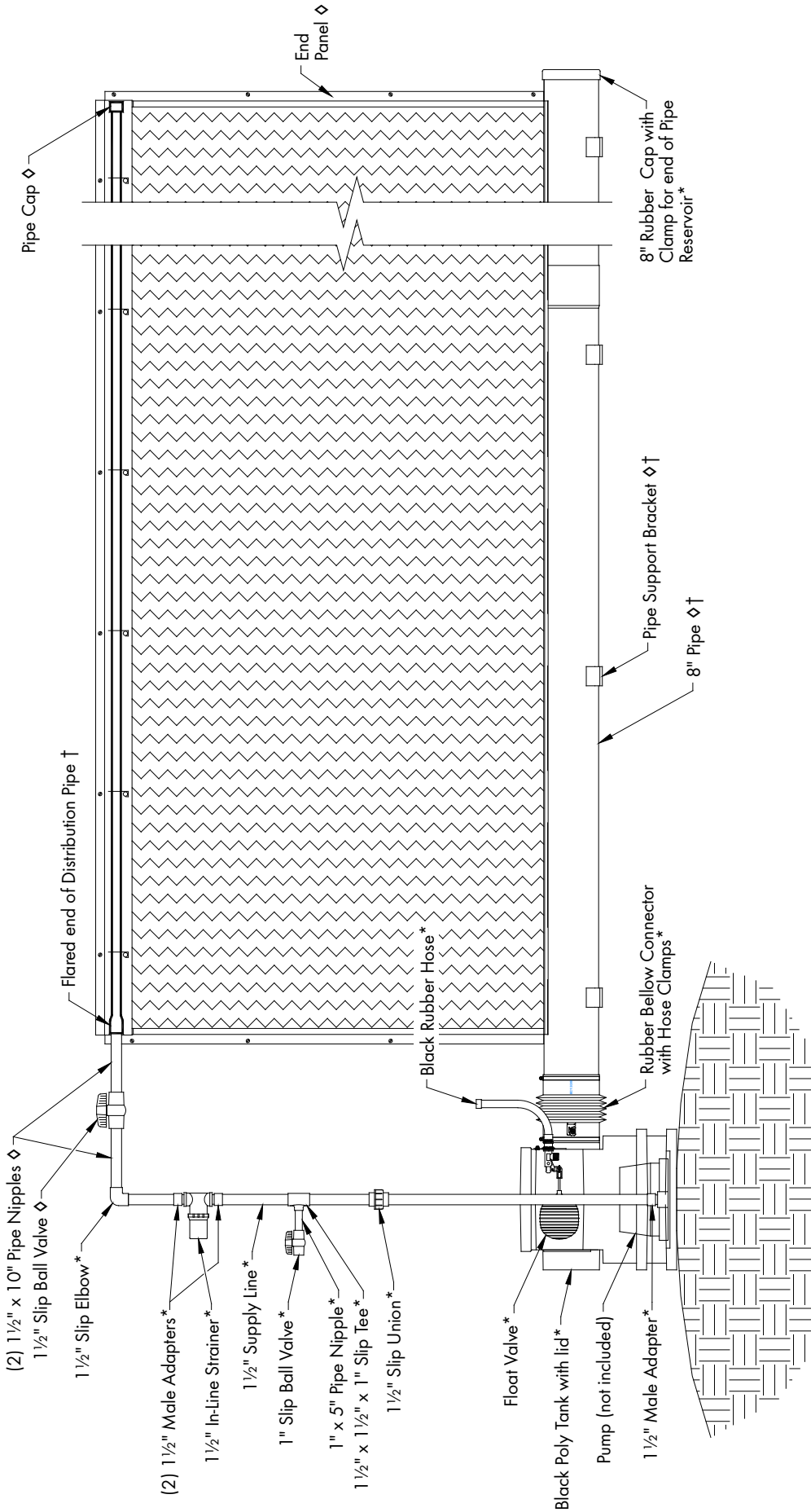

Figure 24
EC1642 BLACK POLY TANK
ELEVATION VIEW WITH SUBMERSIBLE PUMP

† Included with 'CT' cooling
 ◇ Included with ending kit
 * Included in EC1642 Tank Kit

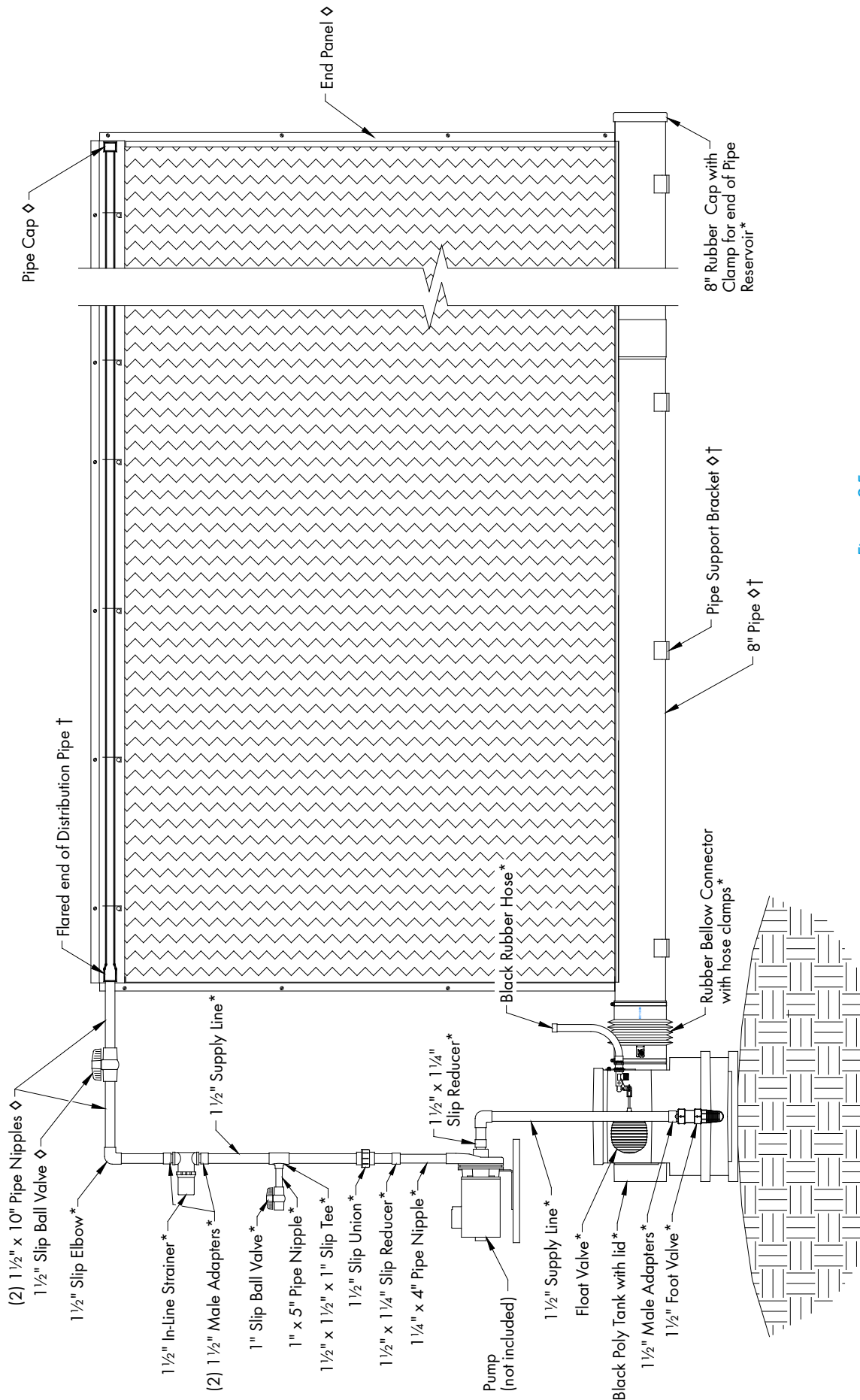

Figure 25
 EC1 644 BLACK POLY TANK
 ELEVATION VIEW WITH NON-SUBMERSIBLE PUMP

† Included with 'CT' cooling
 ◇ Included with 'ending kit
 * Included in EC1644 Tank Kit

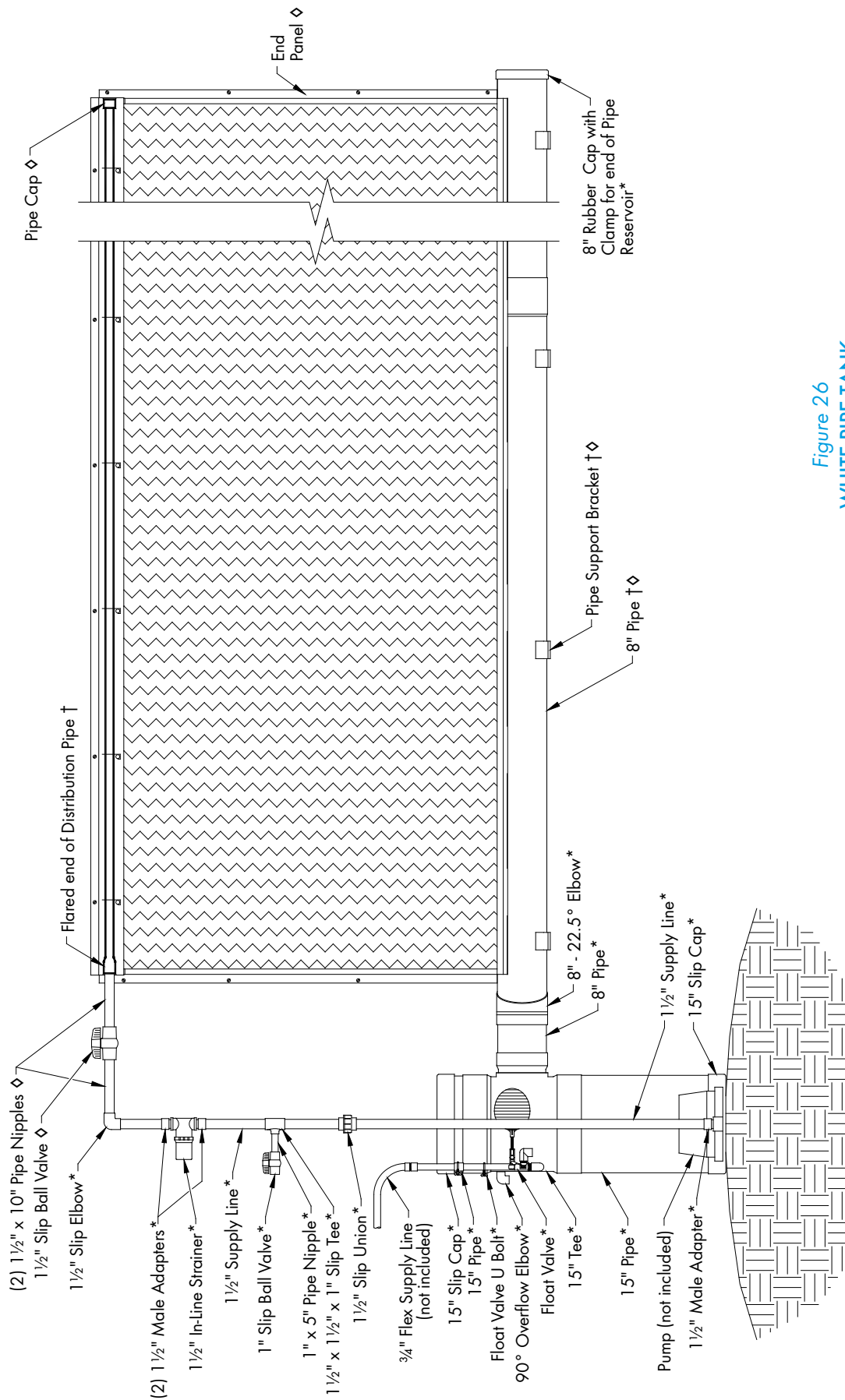

Figure 26
 WHITE PIPE TANK
 EC1606, 15" TANK KIT
 ELEVATION VIEW WITH SUBMERSIBLE PUMP

† Included with 'CT' cooling
 ◇ Included with 'ending kit'
 * Included in EC1606 Tank Kit

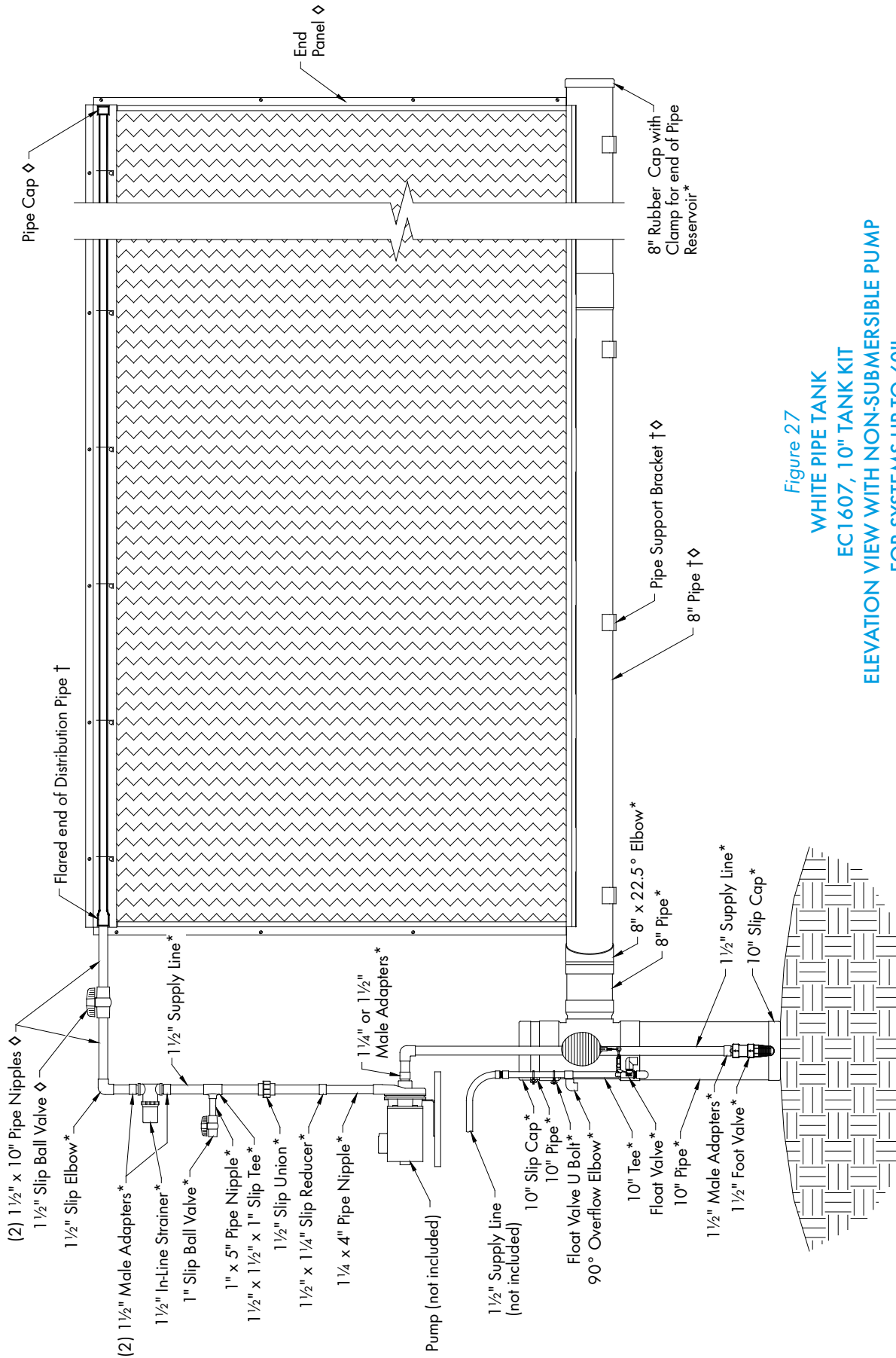

Figure 27
 WHITE PIPE TANK
 EC1607, 10" TANK KIT
 ELEVATION VIEW WITH NON-SUBMERSIBLE PUMP
 FOR SYSTEMS UP TO 60'L.

† Included with 'CT' cooling

◇ Included with 'ending kit

* Included in EC1607 Tank Kit

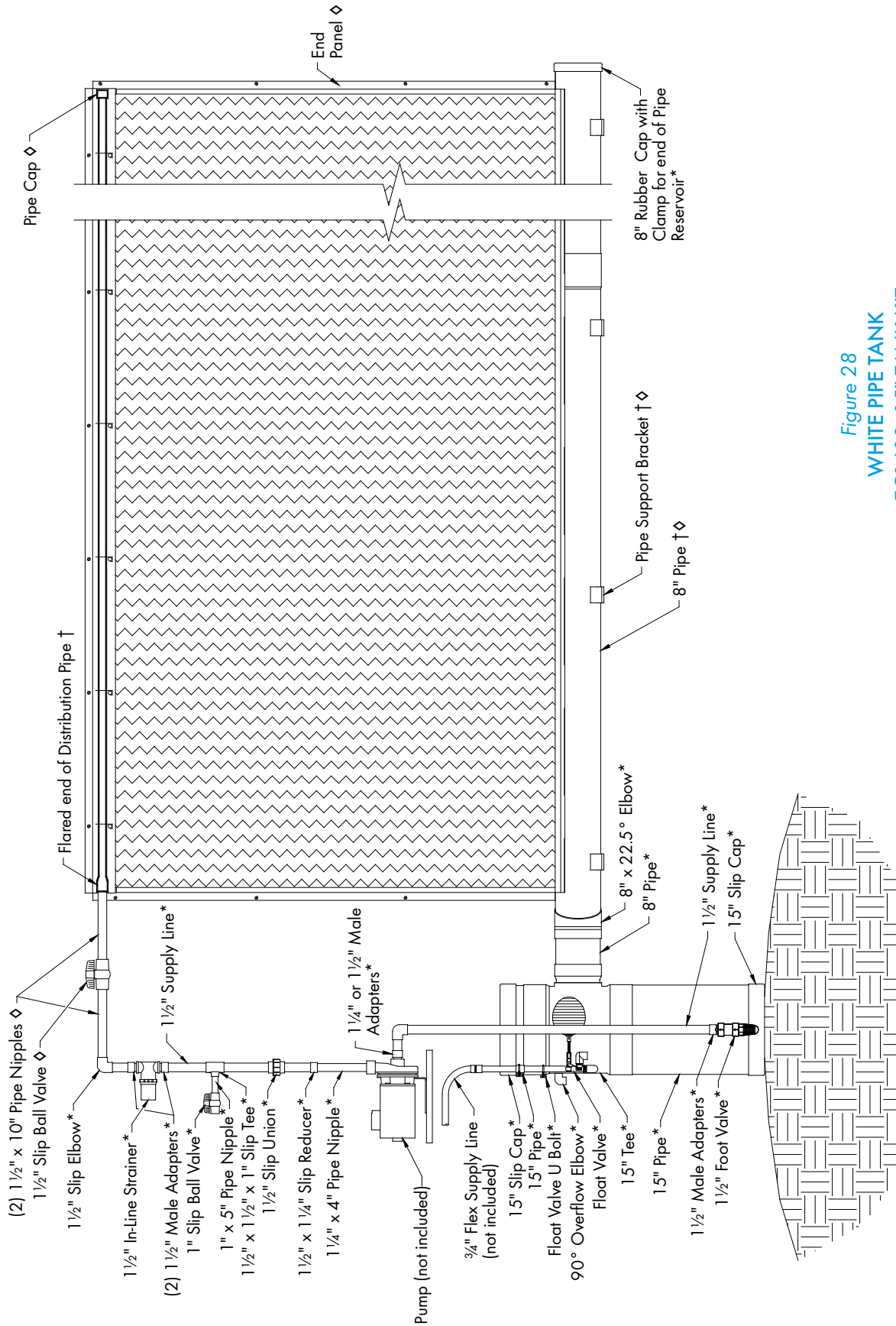
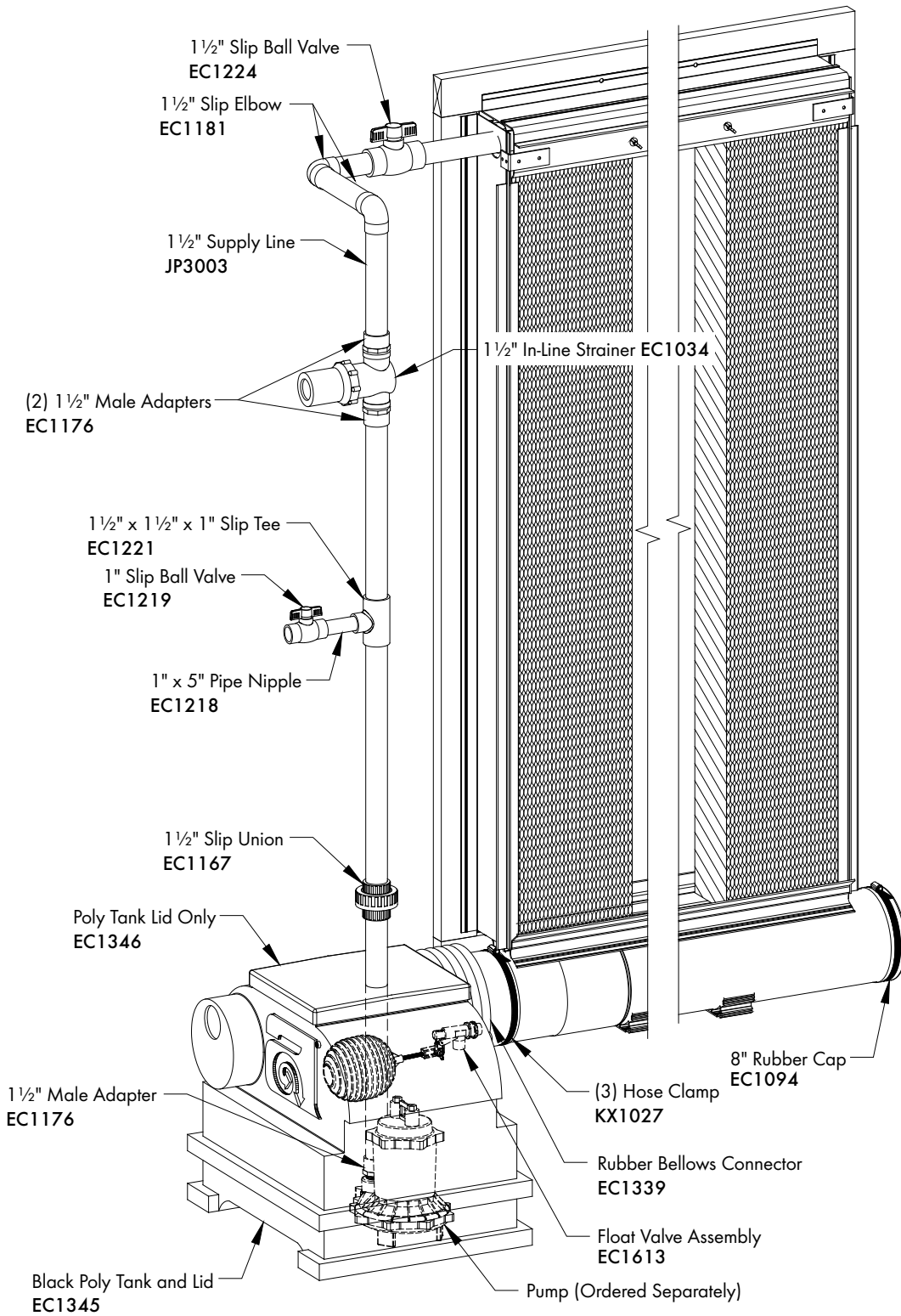

Figure 28
 WHITE PIPE TANK
 EC1608, 15" TANK KIT
 ELEVATION VIEW WITH NON-SUBMERSIBLE PUMP
 FOR SYSTEMS 60' TO 72'L.

† Included with 'CT' cooling
 ◇ Included with 'ending kit'
 * Included in EC1608 Tank Kit

3.5 Plumbing Layout with Black Poly Tank



3.6 Plumbing Layout with White Pipe Tank

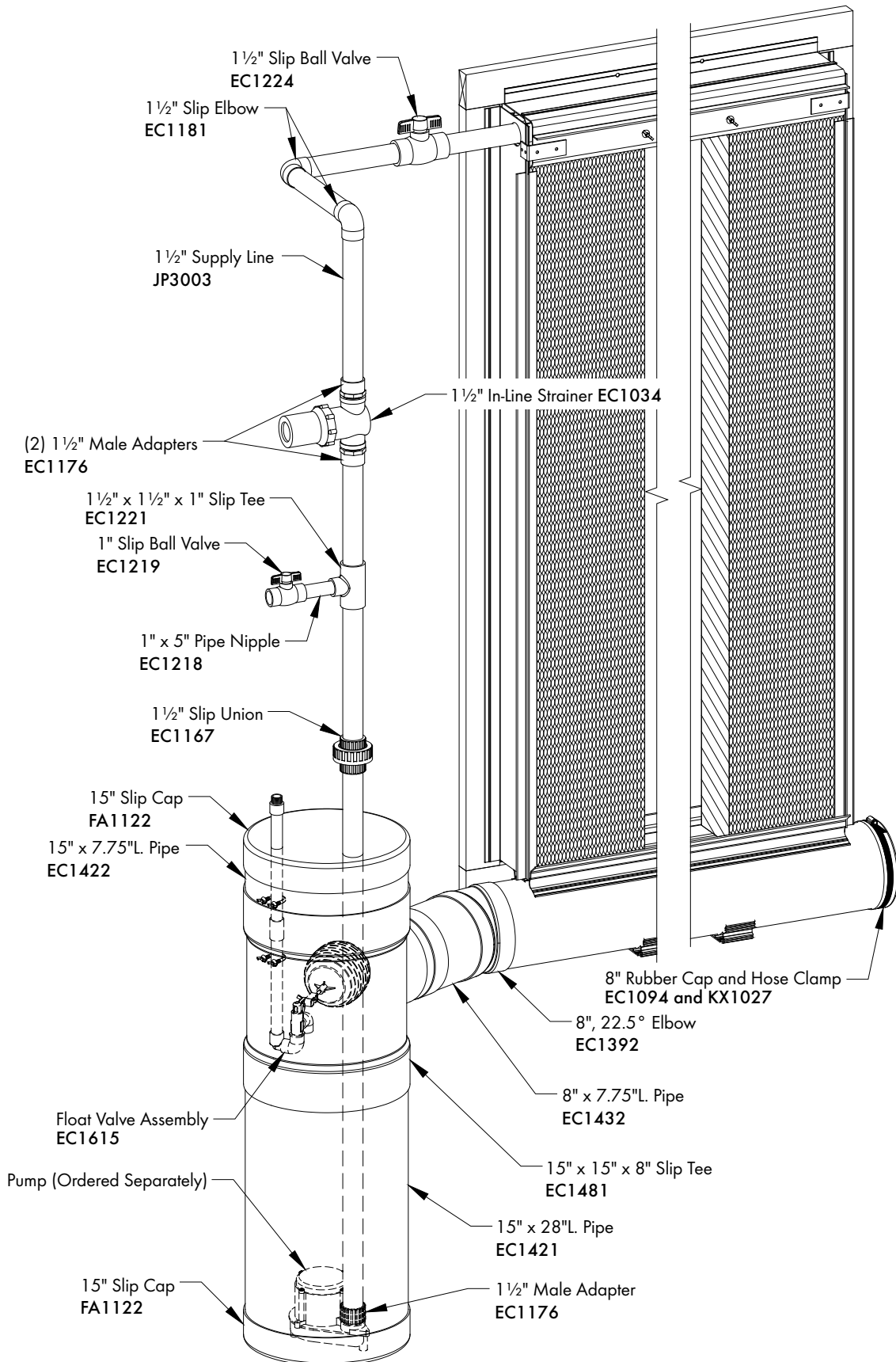

4.1 System Start-up

Step 1

Flush-out 8" Pipe and Tank of any debris before filling with water.

Step 2

Prime pump with water.

Step 3

Turn on the electrical power and fresh water supplies.

Step 4

Activate the pump by setting the cooling thermostat below room temperature.

Step 5

Open the flow control valve at each cooling panel enough to completely saturate the pad material.

Step 6

Adjust the bleed-off valve to discharge water from the cooling system at a rate of 1 gallon per hour per linear foot of cooling system. For example: The bleed off rate for a CB705EF system (70'L.) would be 70 gallons per hour.

4.2 System Operation and Adjustment

Step 1

Set the cooling setpoint on the temperature controller as shown on your Munters Corporation ventilation system drawing. If this is not available contact your Munters field representative for proper settings.

Step 2

Adjust the flow control valve at each cooling panel to give the pad material a "shiny wet" surface. Pad material performs best when as much water as possible is used, but the flow should not be so great that water falls from the material.

Step 3

If the pad material remains dry on one side (with fans running), even at full water flow, adjust the distribution pipe so that the distribution holes are pointing towards the splash deflector.

Step 4

If water drips from the cooling panel's upper edge, the pad material may be loose in its frame. Correct this by tightening the wing nuts on the front of the pad retainer to press it more firmly against the pad material.

Step 5

Water bleed-off is necessary to limit mineral deposits and other contaminants on the pad material by assuring the continuous addition of fresh water. The rate of, **1 gallon per hour per linear foot** of cooling system, should be considered only as a starting point in determining the required amount of bleed-off. Due to differences in water hardness, a trial and error process must be used to determine the correct rate for your location.

After the cooling system has operated for a week or 2, the sump water may become discolored or a light mineral coating may develop on the face of the pad material. If this occurs, increase the bleed-off rate slightly and observe the tendency of the coating to increase or stabilize. If after an extended period of time the mineral deposits become more visible, again increase the bleed-off rate.

Through this trial and error process a bleed-off rate will eventually be established at which the formation of new deposits will cease. Slightly increase the rate from this point to compensate for fluctuations in water hardness. The cooling system should now equalize and now more deposits should form.

5.1 Minimum Maintenance Schedule

To maintain your cooling system in top condition, the recommendations given in this chart should be treated as minimums. More frequent maintenance may be required at initial start-up, in certain climates, and in areas with hard water conditions.

	SCHEDULE		
	Weekly	Monthly	Yearly
Clean the foot valve or the pump filter screen		X	
Flush in-line strainer	X		
Check for dry streaks on pad material	X		
Clean debris from face of pad material	X		
Clean cooling control and sensor		X	
Clean cooling panel distribution pipe holes		X	
Clean cooling panel collection trough			X
Drain and clean sump tank		X	
Clean/check float valve		X	

5.2 Maintenance Checklist



Follow the guidelines below to prevent early pad failure and to get the maximum life from your pads.

1. Reduce the number of on-off cycles. **Do Not** use 10 minute cycle timers on pumps.
2. Shade the pads and sump to minimize algae growth.
3. Dry the pads out completely each night to kill algae. A 24 hour timer may be installed to shut pumps off at 10 PM and not allow them to come on until after 9 AM.
4. Bleed-off some water continuously to prevent concentration of minerals and dissolved chemicals in sump. Start with 1 gallon per hour for each linear foot of cooling system and adjust as necessary.
5. Drain and disinfect the water distribution system every three months to minimize algae, fungus and mineral build-up.
6. Run the recommended quantity of water over the pads. The pump must provide $\frac{3}{4}$ gallon/minute for each linear foot of cooling system for 6" thick pad. For 4" thick pad, provide $\frac{1}{2}$ gallon/minute for each linear foot of cooling system.
7. Periodically check for leaks in water distribution system.
8. Avoid harmful contaminants such as dust, fumes, fertilizers, harsh cleaners and water treatment chemicals.
9. Complete the items on the Maintenance Schedule listed above as required.



Warning:

DO NOT add unapproved chemicals or commercial water treatments to the sump or supply water. If the above recommendations are followed and problems on the pad are observed such as algae growth, mineral deposits or softening of the pad material, contact Munters Corporation for further recommendations.

Exploded View

6.

NOTE: Measure system, length and height before contacting your local representative or Munters office.

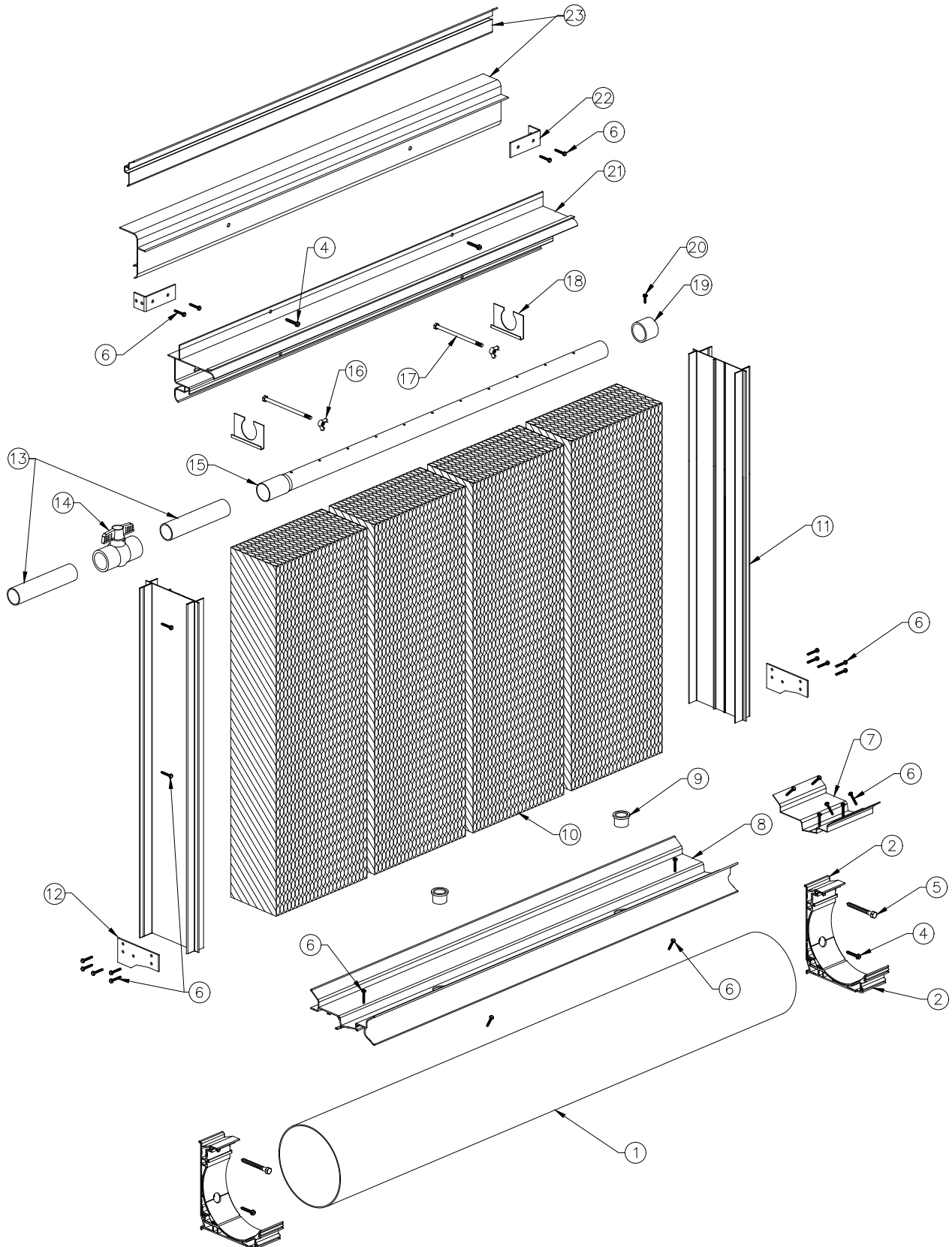

Item	Catalog No.	Description	Qty.
1	JP3028	8" Pipe (SDR81) with Cut Lines, PVC	varies/foot
2	EC1330	Pipe Support Bracket, with Holes, AL	varies/foot
4	KS2105	#14 x 1½" Lag Screw, SS	varies
5	KS2462	¾" x 3½" Lag Screw, HOT DIP GALV.	varies
6	KS2257	#10 x 1¼" TEK Screw, ZP	varies
7	EC1340	Drip Collector Splice, 6"W., PL	varies
8	EC1290	Drip Collector, 2'L., White PVC	varies
	EC1291	Drip Collector, 4'L., White PVC	varies
	EC1296	Drip Collector, 5'L., White PVC	varies
	EC1294	Drip Collector, 10'L., White PVC	varies
9	EC1148	1" x ¾" Drain Fitting, PVC	varies
10*	CEL1545061272M1	CELdek® Pad Material	varies
11	EC1081	End Panel, 83.25"H., PL	2
12	EC1310	Drip Collector End Cap, PL	2
13	EC1299	1½" x 10"L. Pipe Nipple, SDR21, PVC	2
14	EC1224	1½" Ball Valve, Schedule 40, PVC	1
15	EC1498	Pipe, 1.5"D x 10'-2.5"L., w/Holes: ½"D., 3"O.C., Bell, PVC	varies
16	KN2302	⅝"-18 Wing Nut, Type-A, NY, Black Color	varies
17	KS1009	⅝"-18 x 6" Hex Bolt, SS	varies
18	EC1031	Pipe Holder for 1½" Dia. Pipe, AL	varies
19	EC1226	1½" Slip Cap, Schedule 40, PVC	1
20	KS2257	#10 x 1¼" TEK Screw, ZP	varies
21	EC1078	Distribution Cap, 2'L., AL	varies/foot
	EC1072	Distribution Cap, 4'L., AL	varies/foot
	EC1079	Distribution Cap, 5'L., AL	varies/foot
	EC1076	Distribution Cap, 10'L., AL	varies/foot
22	EC1202	Angle Bracket, 1½" x 4" x 1½", AL	2
23	Standard Pad Retainer		
	EC1071	Pad Retainer, 2'L., AL	varies/foot
	EC1065	Pad Retainer, 4'L., AL	varies/foot
	EC1070	Pad Retainer, 5'L., AL	varies/foot
	EC1068	Pad Retainer, 10'L., AL	varies/foot
	OPTIONAL: Open Header Pad Retainer		
	EC1902	Pad Retainer, Open Style, 2'L., AL	varies/foot
	EC1904	Pad Retainer, Open Style, 4'L., AL	varies/foot
	EC1905	Pad Retainer, Open Style, 5'L., AL	varies/foot
	EC1910	Pad Retainer, Open Style, 10'L., AL	varies/foot

* Catalog Number changes depending on type and size of pad.

CT Evaporative Cooling System is developed and produced by Munters Corporation, Lansing, Michigan U.S.A. 1-800-227-2376



Munters Europe AB, Isafjordsgatan 1, P.O. Box 1150, SE-164 26 Kista, Sweden. Phone +46 08 626 63 00, Fax +46 8 754 56 66.

Munters Corporation 2691 Ena Drive Lansing, MI 48917 U.S.A. Phone +1 800-227-2376, Fax +1 517-676-7078

www.munters.us

Australia Munters Pty Limited, Phone +61 2 6025 6422, **Brazil** Munters Brasil Industria e Comercio Ltda, Phone +55 41 3317 5050, **Canada/US** Munters Corporation Lansing, MI Phone +1 517 676 7070, **China** Munters Air Treatment Equipment (Beijing) Co. Ltd, Phone +86 10 80 481 121, **Denmark** Munters A/S, Phone +45 9862 3311, **India** Munters India, Phone +91 20 3052 2520, **Indonesia** Munters, Phone +62 818 739 235, **Italy** Munters Italy S.p.A., Chiusavecchia, Phone +39 0183 52 11, **Japan** Munters K.K., Phone +81 3 5970 0021, **Korea** Munters Korea Co. Ltd., Phone +82 2 761 8701, **Mexico** Munters Mexico, Phone +52 818 262 54 00, **Russia** Munters AB, Phone +7 812 448 5740, **Singapore** Munters Pte Ltd., Phone +65 744 6828, **South Africa and Sub-Sahara Countries** Munters (Pty) Ltd., Phone +27 11 997 2000, **Spain** Munters Spain S.A., Phone +34 91 640 09 02, **Sweden** Munters AB, Phone +46 8 626 63 00, **Thailand** Munters Co. Ltd., Phone +66 2 642 2670, **Turkey** Munters Form Endüstri Sistemleri A.Ş, Phone +90 322 231 1338, **USA** Munters Corporation Lansing, MI Phone +1 517 676 7070, **Vietnam** Munters Vietnam, Phone +84 8 3825 6838, **Export & Other countries** Munters Italy S.p.A., Chiusavecchia Phone +39 0183 52 11