

# Instruction Manual



**FH1389**  
**WM5415K1**  
Sheave/V-Belt  
Replacement Kit

**FH1389**

WM5415K1 Sheave/V-Belt



# FH1389 WM5415K1 Sheave/V-Belt Replacement Instructions for Use and Maintenance

## Thank You:

Thank you for purchasing a WM5415K1 Replacement Kit. Munters equipment is designed to be the highest performing, highest quality equipment you can buy. With the proper installation and maintenance it will provide many years of service.

## Please Note:

To achieve maximum performance and insure long life from your Munters product it is essential that it be installed and maintained properly. Please read all instructions carefully before beginning installation.

## Warranty:

For Warranty claims information see the "Warranty Claims and Return Policy" form QM1021 available from the [Munters Corporation office at 1-800-227-2376 or by e-mail at aghort.info@munters.com](mailto:aghort.info@munters.com).

## Conditions and Limitations:

- Products and Systems involved in a warranty claim under the "Warranty Claims and Return Policy" shall have been properly installed, maintained and operated under competent supervision, according to the instructions provided by Munters Corporation.
- Malfunction or failure resulting from misuse, abuse, negligence, alteration, accident or lack of proper installation or maintenance shall not be considered a defect under the Warranty.

# Index

Chapters	Page
1. Unpacking the Equipment	4
1.1 Parts List	4
2. Installation Instructions	5

# Unpacking the Equipment

# 1.

## 1.1 Parts List

Each Munters Sheave/Belt Replacement Kit includes:

1 - Sheave, CI

1 - V-Belt, POLYSTR CORD

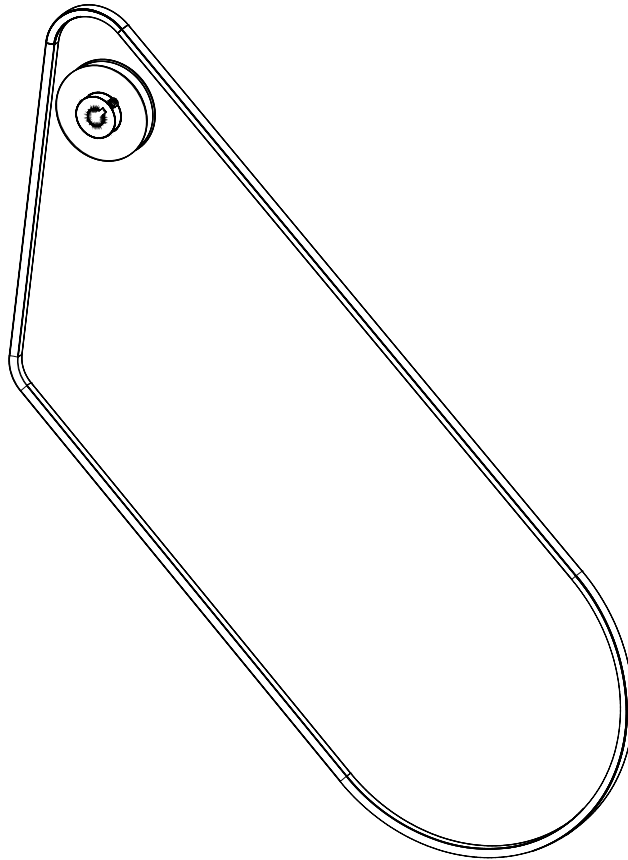

# Installation Instructions

# 2.

## 2.1 Installation

### Step 1

Disconnect power from fan before continuing. Remove the rear guard from the back of the fan and set safely aside to be reinstalled later. [See Figure 1.](#)

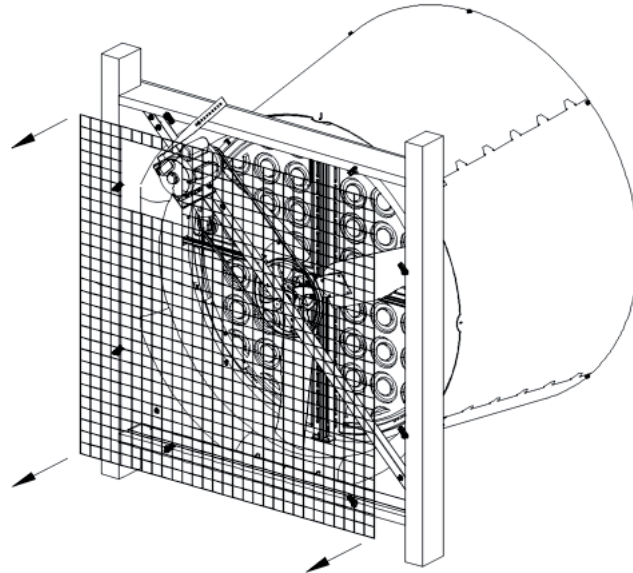

Figure 1

### Step 2

Disconnect the electrical power leads from the motor. Remove belt from fan. Spray a penetrating lubricant on the motor shaft where the sheave is attached and allow it time to work. [See Figure 2.](#)

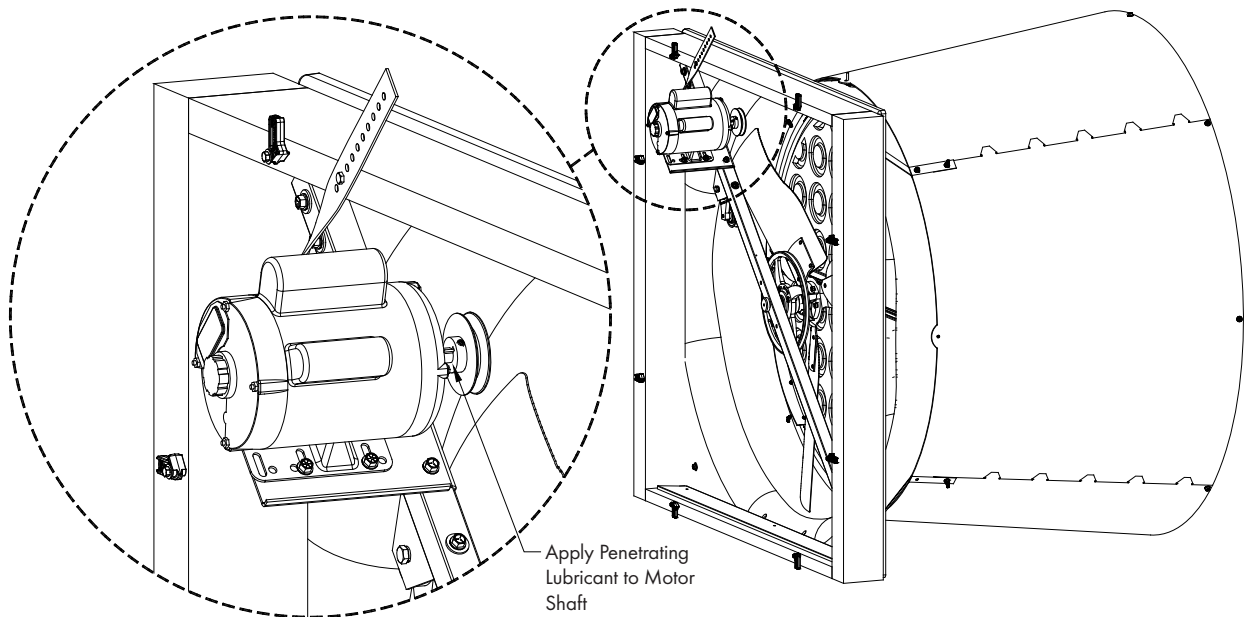

Figure 2

**Step 3**

Remove lag screw from stiffener bracket. Remove the (2) bolts and nuts holding the motor base to strut and remove motor with base from fan. See Figure 3.

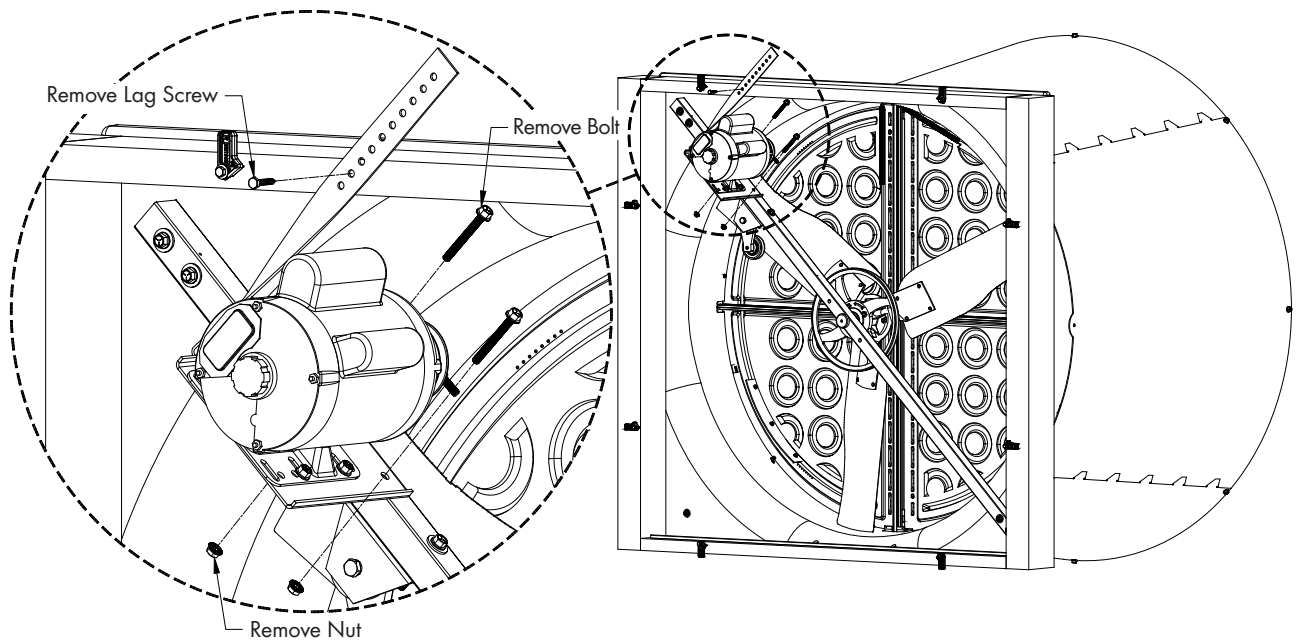

Figure 3

**Step 4A**

Loosen the set screw on the motor sheave. Using a gear puller remove the sheave from the motor shaft. Be sure to keep Key to be reused. After sheave is removed clean the motor shaft and key, make sure they are clear of any debris. See Figure 4A.

**Step 4B**

Using the Key saved in the last step, place it in the Keyway on the motor shaft. Place the Motor Sheave on the Motor shaft with the hub facing towards the motor. See Figure 4B. ONLY tighten the set screw enough to hold the Sheave in place at this time.

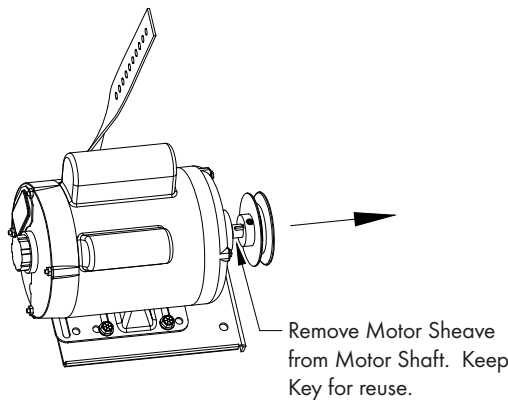

Figure 4A

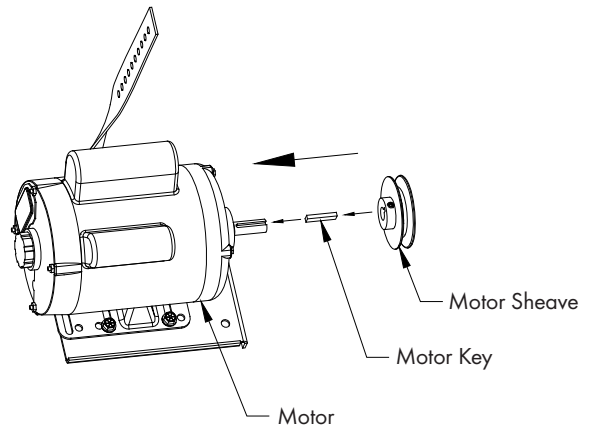

Figure 4B

**Step 5**

Reattach Motor Base with Motor to Strut using the (2) Bolts and Nuts removed in Step 3. The lower bolt should go through the Motor Base, Strut and Tensioner Bracket. Once Motor Base with Motor is secured, reattach Motor Bracket Stiffener to framing using Lag Screw removed in Step 3. See Figure 5.

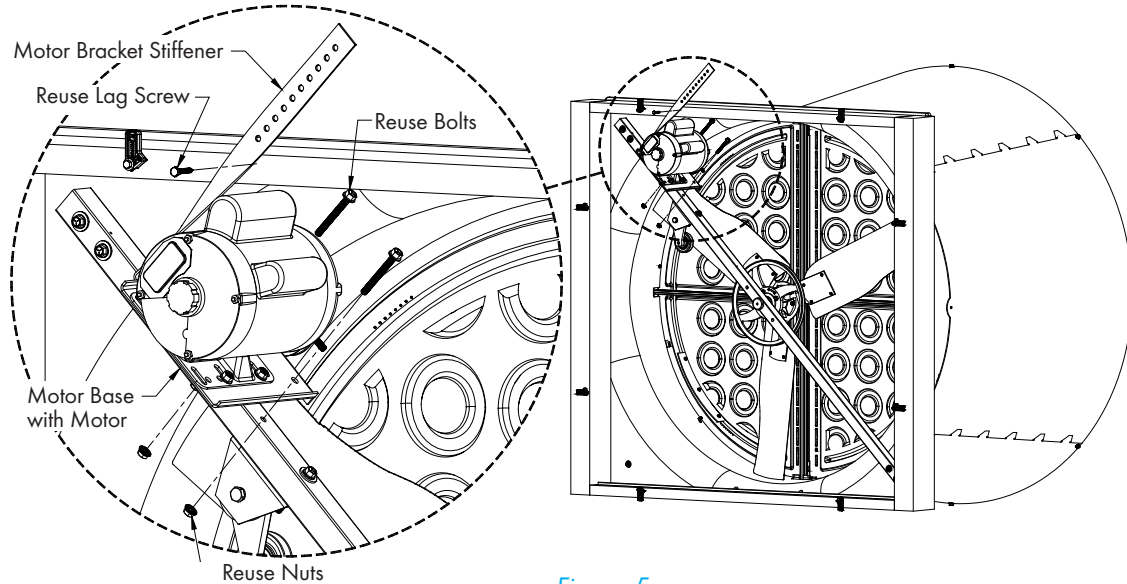

Figure 5

**Step 6**

Use a straight edge or level to check alignment of Propeller Sheave, Tensioner Pulley and Motor Sheave. If needed, adjust position of Motor Sheave so the 3 pulleys line up. Once Motor Sheave is aligned tighten the set screw to 75 in-lbs [9 N·m] torque. See Figure 6.

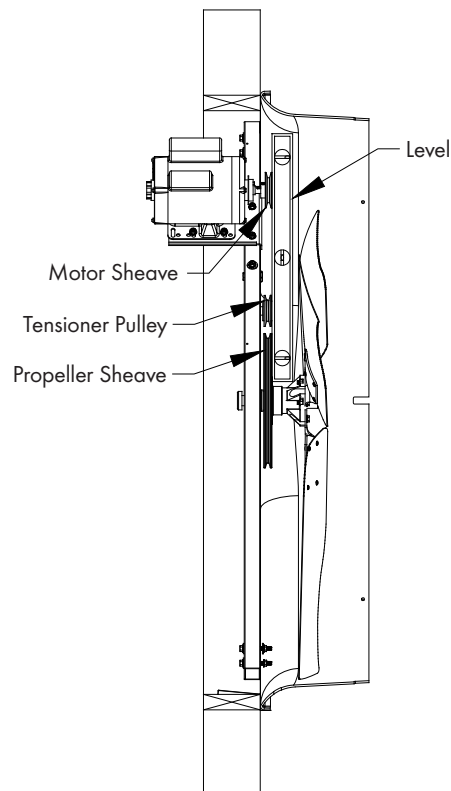

Figure 6

Step 7

Slide new V-belt over Propeller and install by wrapping it around 2 smaller pulleys and starting it over larger Sheave. Continue rolling it onto the larger Sheave until it fits into groove. [See Figure 7.](#)

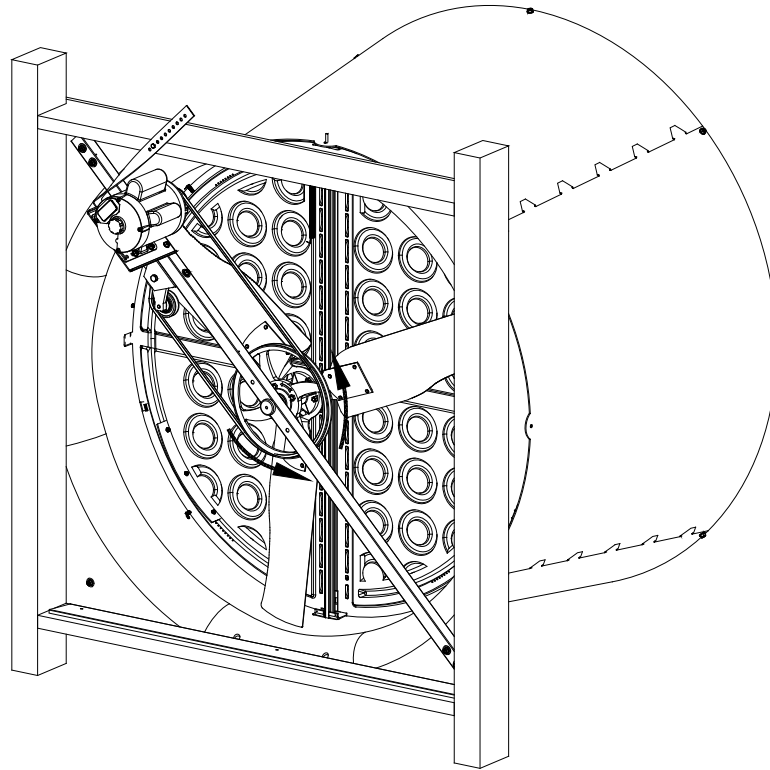

Figure 7

Step 8

To adjust belt tensioner to proper setting, loosen 10 mm bolt (using 17mm end wrench) to allow tensioner arm to rotate. Working from inlet/motor side of fan, place a 27 mm (1 1/16") wrench onto the hex on the tensioner. Turn wrench clockwise until the single mark on base of belt tensioner is aligned with Mark 2 on tensioner arm. Hold tensioner at this setting and tighten the 10mm bolt to 40 ft.-lbs [54 N-m] torque. [See Figure 8.](#)

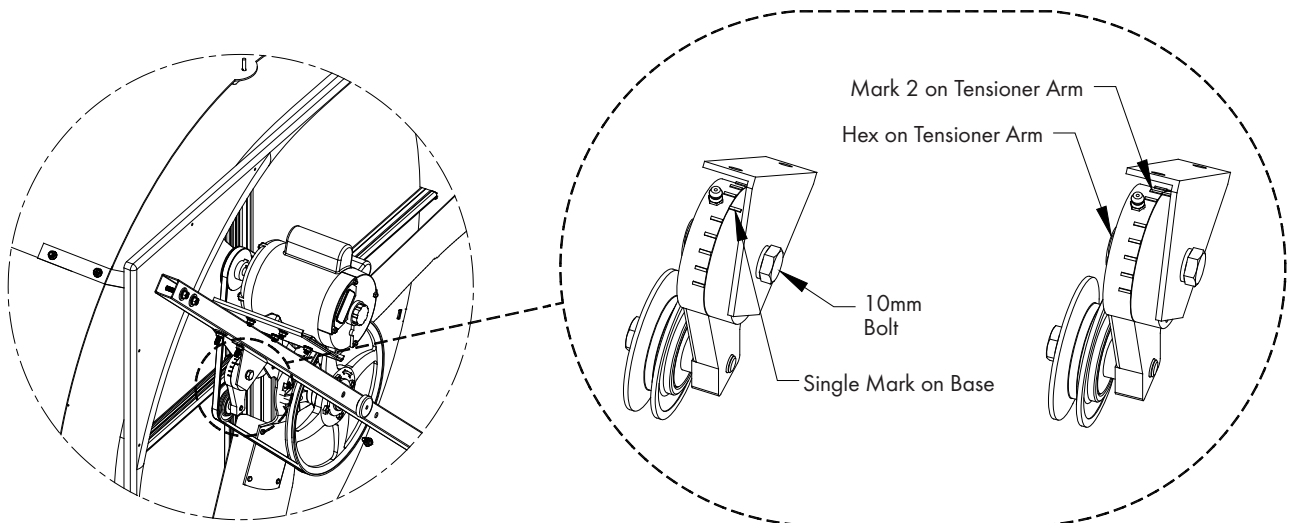

Figure 8



**Step 9**

Reconnect power to Motor. Replace guard against framing with the hole in the guard over the motor and secure in place using the existing shutter clips. See Figure 9.

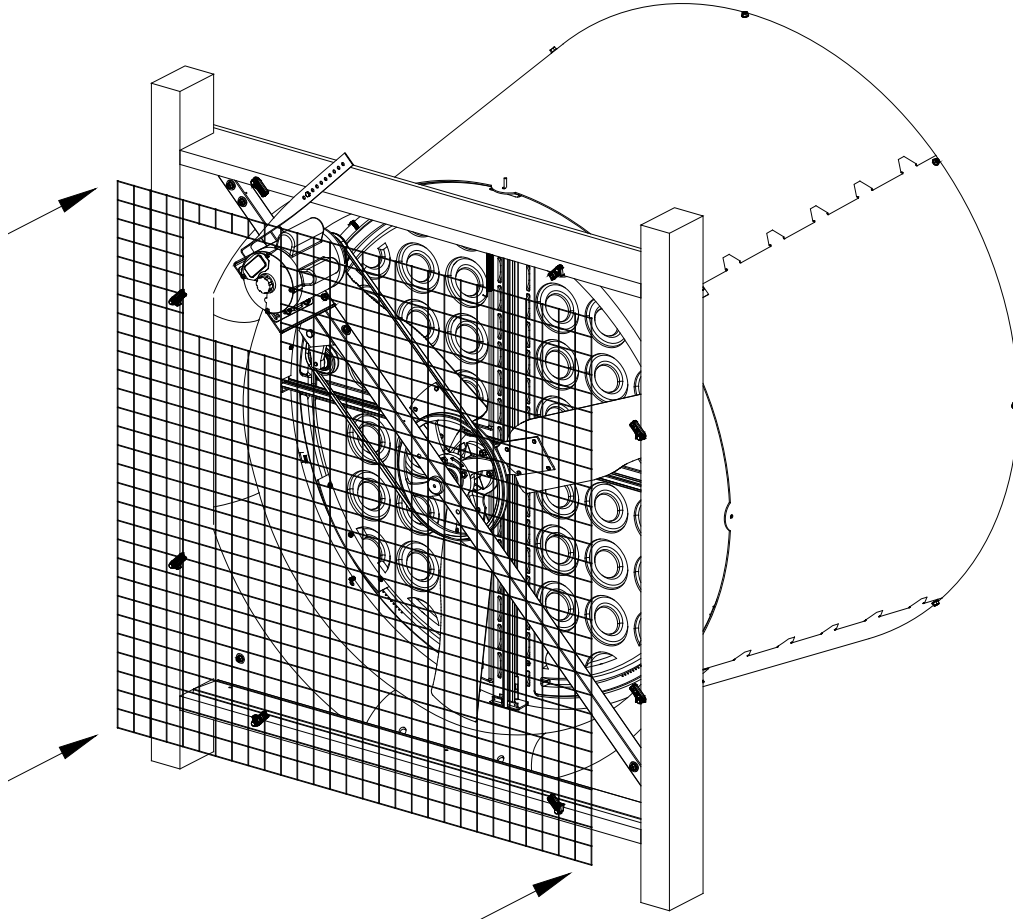

Figure 9

Installation is now complete.

WM54 Sheave/V-belt Replacement Kit is developed and produced by Munters Corporation, Lansing, Michigan U.S.A. 1-800-227-2376



Munters Europe AB, Isafjordsgatan 1, P.O. Box 1150, SE-164 26 Kista, Sweden. Phone +46 08 626 63 00, Fax +46 8 754 56 66.

Munters Corporation 2691 Ena Drive Lansing, MI 48917 U.S.A. Phone +1 800-227-2376, Fax +1 517-676-7078

[www.munters.us](http://www.munters.us)

**Australia** Munters Pty Limited, Phone +61 2 6025 6422, **Brazil** Munters Brasil Industria e Comercio Ltda, Phone +55 41 3317 5050, **Canada/US** Munters Corporation Lansing, MI Phone +1 517 676 7070, **China** Munters Air Treatment Equipment (Beijing) Co. Ltd, Phone +86 10 80 481 121, **Denmark** Munters A/S, Phone +45 9862 3311, **India** Munters India, Phone +91 20 3052 2520, **Indonesia** Munters, Phone +62 818 739 235, **Italy** Munters Italy S.p.A., Chiusavecchia, Phone +39 0183 52 11, **Japan** Munters K.K., Phone +81 3 5970 0021, **Korea** Munters Korea Co. Ltd., Phone +82 2 761 8701, **Mexico** Munters Mexico, Phone +52 818 262 54 00, **Russia** Munters AB, Phone +7 812 448 5740, **Singapore** Munters Pte Ltd., Phone +65 744 6828, **South Africa and Sub-Sahara Countries** Munters (Pty) Ltd., Phone +27 11 997 2000, **Spain** Munters Spain S.A., Phone +34 91 640 09 02, **Sweden** Munters AB, Phone +46 8 626 63 00, **Thailand** Munters Co. Ltd., Phone +66 2 642 2670, **Turkey** Munters Form Endüstri Sistemleri A.Ş, Phone +90 322 231 1338, **USA** Munters Corporation Lansing, MI Phone +1 517 676 7070, **Vietnam** Munters Vietnam, Phone +84 8 3825 6838, **Export & Other countries** Munters Italy S.p.A., Chiusavecchia Phone +39 0183 52 11