

# Mounting instructions

Fresh Air Inlet  
»ZEW« Flatwave

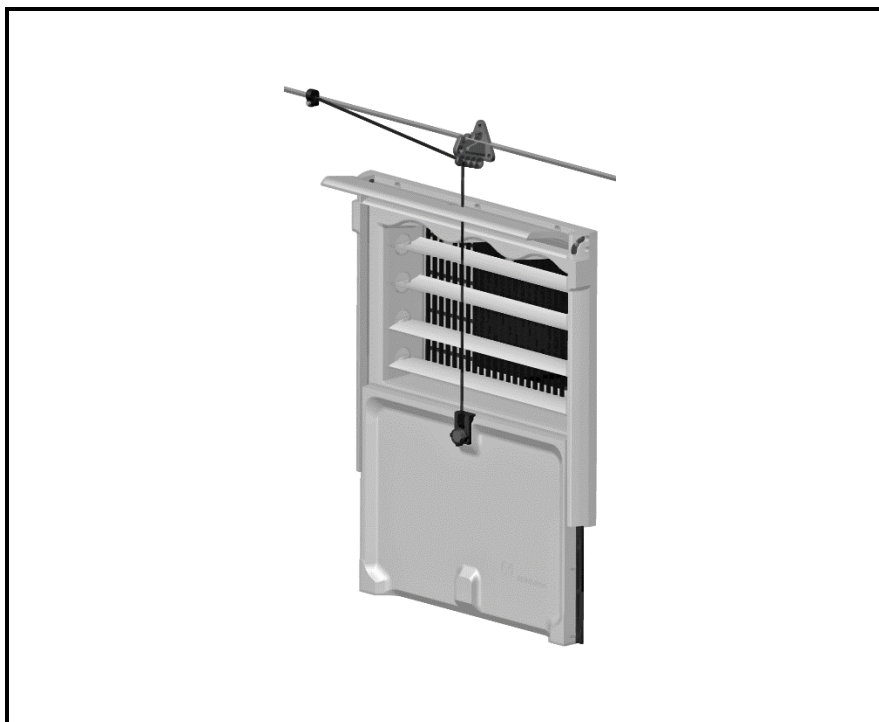

## Fresh Air Inlet

### »ZEW« Flatwave

2600 automatic opening (a.o.)

2600 automatic opening (a.o.), including bird protective grid

## Information page

Description	Fresh Air Inlet »ZEW« Flatwave
Versions	2600 automatic opening (a.o.) 2600 automatic opening (a.o.), including bird protective grid
Year of construction	2021
Manufacturer	REVENTA GmbH Im Gewerbegebiet 3 48612 Horstmar Germany
Instruction number	9702078E
Item code	202260000 – 2600 automatic opening 202260100 – 2600 automatic opening, including bird protective grid

This document is the translated version.

Revision index	Modification undertaken	Implemented by	Date

# 1 General Safety Instructions for Mounting Systems and System Components

**IMPORTANT**  
**READ CAREFULLY BEFORE USE**  
**KEEP FOR REFERENCE PURPOSES**

## 1.1 General







The system and system component parts correspond to the state of the art and - if required - to the applicable harmonized standards. However, particularly in mounting and repair work, use of the system may create hazards for the user or third parties or lead to the system or other material assets being adversely affected.

Before any mounting work, inform yourself in the operating and mounting instructions of all components about the structure of the system and about the required work steps in order to execute all work safely and correctly.

The particulars in the operating and mounting instructions correspond to the manual as issued but may differ from the as-delivered condition given further development of the system component parts. Therefore, no claim to any corrective work or a replacement delivery can be derived from images and drawings at variance with the instructions as issued. Errors excepted.

All the content and, in particular, texts and images of the instructions are protected by copyright. All rights including those of duplication, publishing, editing and translation are reserved with Reventa GmbH. Please contact us if you want to use any content of this manual.

## 1.2 Information on selecting personal protective equipment

	Wear a hard hat if at risk both from bumping into objects as well as from falling, swaying and toppling over objects.		On construction sites, do wear safety shoes with toe protection caps and anti-slip, sure-footed soles.
	Protective masks protect from dust, gas and vapour hazards.		Wear protective clothing as a protection from the elements, from getting caught, from chemical effects and for maintenance purposes.
	Wear protective goggles to protect eyes from mechanical, thermal, biological, electrical and chemical dangers.		Wear safety gloves which are suitable as a protection from mechanical/thermal or chemical hazards.
	Ear muffs are to be provided from 80 dB(A) on and must be worn from 85dB(A) on.		

## 1.3 Requirements for the qualification of the mounting personnel

This applies to all personnel irrespective of the employment relationship or company affiliation. Qualification of the groups of persons must comply with the national workplace safety legislation.

### Definition of technical qualifications





Term	Definition
Authorised specialist	Having received instruction from the manufacturer, the authorized service provider or from a company assigned by the manufacturer.
Specialist	Is professionally trained, experienced and instructed and also has knowledge of the relevant standards, requirements, accident prevention regulations and operating conditions. Is authorized to carry out the required operations and can both detect and avoid any dangers.
Trained and instructed person	Instructs on tasks and on potential dangers due to inappropriate conduct. If necessary, trained on-the-job and instructed about protective equipment and safeguards.

### Definition of the target group and allocation of the tasks and qualification:

Target group	Definition	Qualification
Operator	In-depth knowledge of the subject, specific circumstances and the resulting dangers. Responsible for compliance with the technical guidelines and implementation of the required protective equipment and safeguards by the persons appointed by him.	Specialist
Qualified personnel	Carry out work and mounting steps in keeping with their qualification e.g. installing gas, electrical equipment and electronic components and handling chemical substances.	Specialist
Assembly personnel	Are trained in handling and operating the required tools. Carry out work under the direction and supervision of a qualified person, e.g. preliminary work, straightforward mounting work with consideration given to the required safeguards.	Trained and instructed person
Authorized specialists	Carry out work for which they have received specific instructions, e.g. mounting work, commissioning.	Authorised specialist





## 1.4 Notes for reading the mounting instructions

### Graphic symbols used

Warning symbol	Type of danger
	General warning
	Warning of electrical voltage
	Warning of being pulled in and caught
	Warning of automatic start-up
	Warning of hand injury

### Signs used and meaning of the signal words in safety warnings

Safety warnings warn against injury and damage that can arise from not following the signs. The signs point to differing major risks (Danger, Warning and Caution).

	<b>DANGER</b>	<b>Extremely dangerous situation</b> Disregarding the safety sign results in death or severe injuries.
	<b>WARNING</b>	<b>Dangerous situation</b> Disregarding the safety sign can result in death or severe injuries.
	<b>CAUTION</b>	<b>Dangerous situation</b> There is a potential risk of injuries from disregarding the safety sign. There is also the risk of damage from not following the instructions.
	<b>NOTE</b>	Notes are used to point to a particular circumstance or to provide assistance.

### Information on reading mounting and operating instructions

The safety warnings in this manual refer solely to the mounting work. Refer to the operating instructions for information on operation, maintenance, cleaning and repairs.

Safety warnings always precede the passages in which they are of relevance.

The information on the previous pages is understood to be a requirement for each of the mounting instructions and, as such, is not repeated. This does not apply to safety warnings.

### Rules of conduct during mounting work

Safe mounting and fail-safe operations depend, for instance, on the tools, auxiliary equipment, media and energies being used carefully and as intended.

Any changes or modifications to system components are only permitted after consulting the manufacturer and receiving his written approval.

Wear the Personal Protective Equipment (PPE) for your own safety. Corresponding information on wearing the PPE can be found in the mounting and operating instructions of the components.

Tie long hair together. Remove any jewellery, watches and rings before working on the system. Do not wear any loose and fluttering clothing when working on the system. Clothes, hair and jewellery could get caught in moving components!

Store and handle components properly. Protect components from moisture, dirt and damage. Check components for damage before mounting. Damaged components must not be used.

Follow the national regulations and legislation on accident prevention and safety on construction sites and with mounting work.

## 1.5 Specific dangers

---

### Working at heights

Working at heights may be necessary when mounting system components. Wear the personal protective equipment intended for the task. Ensure that the workplace is secured.

### Caustic substances and vapours

Caustic or otherwise harmful liquids e.g. sulphuric acids, may be used in system components. The concentration of the operating substances used must not be above the specified values. Under certain circumstances, caustic or otherwise harmful gases could be released by these liquids. Wear the personal protective equipment intended for the task.

Only use operating substances and cleaning agents authorized by the system manufacturer.

Before work on interconnection points or other interventions in the system, ensure that the system is not in service and/or cannot be started and is secured from being accidentally started!

### Moving/ rotating parts

Components may re-set or be set in motion caused by mounting, maintenance and repair work. Ensure that all components are at a standstill and/or are secured against moving spontaneously.

### Biohazard

High micro-organism concentrations in water can arise in systems in which water trickles or is sprayed. Avoid any contact with water. Wear the personal protective equipment intended for the task.

### Pressure

System parts may become pressurized during the operation. There is a risk of gases and/or liquids escaping during the installation. Before opening the system parts, ensure that the components are depressurized.

### Electrical voltage

Working on electrical components/sub-assemblies must only be carried out by qualified electricians or authorized specialists under the direction and supervision of a qualified electrician in accordance with the electrical engineering regulations. The operator must ensure that the electrical systems are operated, serviced and maintained in accordance with the electrical engineering regulations.

Life-threatening voltages may arise when working on electrical systems. Only work on the electrical system when the power supply is disconnected and when the lack of voltage has been confirmed by means of a two-pole voltage tester.

Do not mount control equipment in the stable. There is a potential risk of corrosion from ammonia (NH<sub>3</sub>) vapours. Do not cover electric motors! Fire hazard due to heat accumulation.

### Flammable gases

Only specialists may work on gas-conveying components/sub-assemblies and work must comply with the technical guidelines for gas installation. The operator must ensure that the gas-conveying systems are operated, serviced and maintained in accordance with the technical guidelines for gas installation.

Working on the gas installation may cause combustible gases to escape and explosive concentrations may be reached. Only carry out work on the gas-conveying system when the shut-off mechanism is locked and secured against being unlocked by non-authorized persons and when the pipe is depressurized and the gas has been safely discharged.

### Spring forces

Mounting, maintenance and servicing work may result in spontaneous movements from spring-tensioned components. Ensure that the springs are stress-relieved prior to the respective work.

### Hot liquids

System-filled liquids may still be extremely hot even when the system is switched off. For work on hot liquids, the personal protective equipment intended for the task is to be worn or a sufficient time for cooling kept to.

### Hot surfaces

System components may still be extremely hot even after the system is switched off. For work on hot systems, the personal protective equipment intended for the task is to be worn or a sufficient time for cooling kept to.

## 1.6 Essential requirements for reliable commissioning

---

The installation can be put into operation safely:

- When all the relevant components and safety devices (fixed, moving and electrical safety components) are mounted and in working order.
- When all components are in perfect technical condition.
- When all external contacts and connections comply with applicable safety regulations.
- After consultation with all trades.

In addition, when electrical connections were necessary:

- When all control devices, switching devices and control units are closed or fitted in the control cabinet.
- When the fuses provided in the electrical circuit diagram are fitted.
- When all cables have been examined for any visible damage and, if necessary, replaced.
- When connected loads are not exceeded.

In addition, when a gas installation was necessary:

- When all work on the gas installation pipes is finished.
- When the seal tightness of the gas installation is established.
- When all outlets are tightly shut.
- When any escaping gas has been safely directed to the atmosphere.
- When air supply and exhaust gas discharge is assured without hindrance.
- When the installation company has instructed the operator on handling and servicing the entire system and has handed over the operating instructions and servicing information.

## 1.7 Disposal

---

After the system has been fully installed, the packaging materials and non-recyclable waste or residues must be sent for recycling or disposal in accordance with statutory regulations.

## 1.8 Warranty and liability

---

Warranty and liability claims of individuals and material damage are ruled out should they be attributable to one or several of the following reasons:

- Improper use of the system.
- Incorrect mounting, commissioning, operating, maintaining and repairing the system.
- Operating the system despite defective safeguards or improperly attached or malfunctioning safety and protective equipment.
- Disregarding the information in the operating manual on transporting, storing, mounting, commissioning, operating, maintaining, cleaning and equipping the system.
- Non-authorized structural changes to the system.
- Non-authorized change of product at the hardware and software (e.g. drive ratio: power and speed, change to the software and performance parameters).
- Inadequate monitoring of system components subject to wear.
- Catastrophes resulting from foreign body effects and force majeure.



## 2 Instructions for fresh air inlets

### 2.1 Basic instructions

#### Tension-free installation

Eliminate any deformation in fresh air inlets during installation. Deformed fresh air inlets are not air-tight, meaning daylight and air can penetrate. Carrying out installation as described prevents deformation in the fresh air inlets. Do not install fresh air inlets which are tensioned.

#### Wind and weather shield

Install the fresh air inlet with a wind and weather shield if wind, snow, ice or sunlight could possibly have a negative impact on the supply air system. A wind and weather shield ensures that the supply air system will function more reliably.

#### Drive for fresh air inlets

We only recommend using the REVENTA GmbH M8 pull rod and electrical cylinders to open and close fresh air inlets. The maximum permitted tensile force is 3000 N.

### 2.2 Wall outlets



#### NOTE

Fresh air inlets must be free of tension when installed.  
You will permanently damage the fresh air inlet if you build over it directly.  
Leave a 10 mm distance around the vent.  
Install wall air inlet in a level, right-angled position.  
Support with a prop in the centre while foaming it into position.

#### Recess

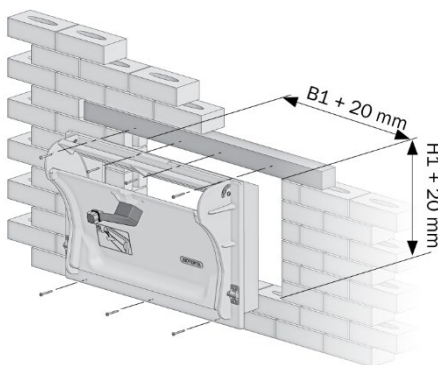

Create a wall opening. You will find the dimensions of wall air inlets in the technical data.

## Installation

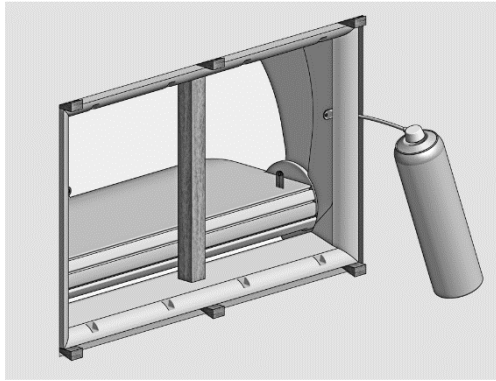

- Insert fresh air inlet into wall recess.
- Use installation aids to centre it.
- Support with added prop in centre (made of wood, for example).
- Fasten wall air inlet onto wall.
- Foam in distance with light expanding spray foam. Observe manufacturer's instructions.
- Remove installation aids after hardening.

## 2.3 Ceiling outlets



### NOTE

Fresh air inlets must be free of tension when installed.  
Leave a 10 mm distance around the vent.

## Recess

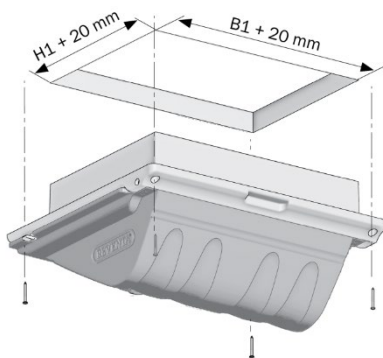

Create an opening in the ceiling. You will find the dimensions of wall air inlets in the technical data.

## Installation

- Insert fresh air inlet into ceiling recess.
- Position fresh air inlet and fasten with screws. (Screws not included in the installation set).
- Foam spaces between ceiling and fresh air inlet with light expanding spray foam; observe manufacturer's instructions in doing so.

## 2.4 Position of the rope guide with wall guide

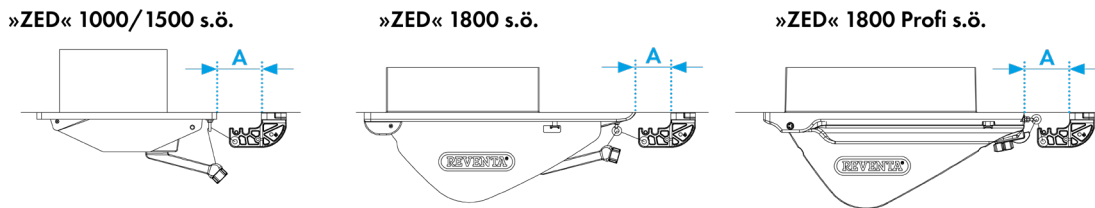
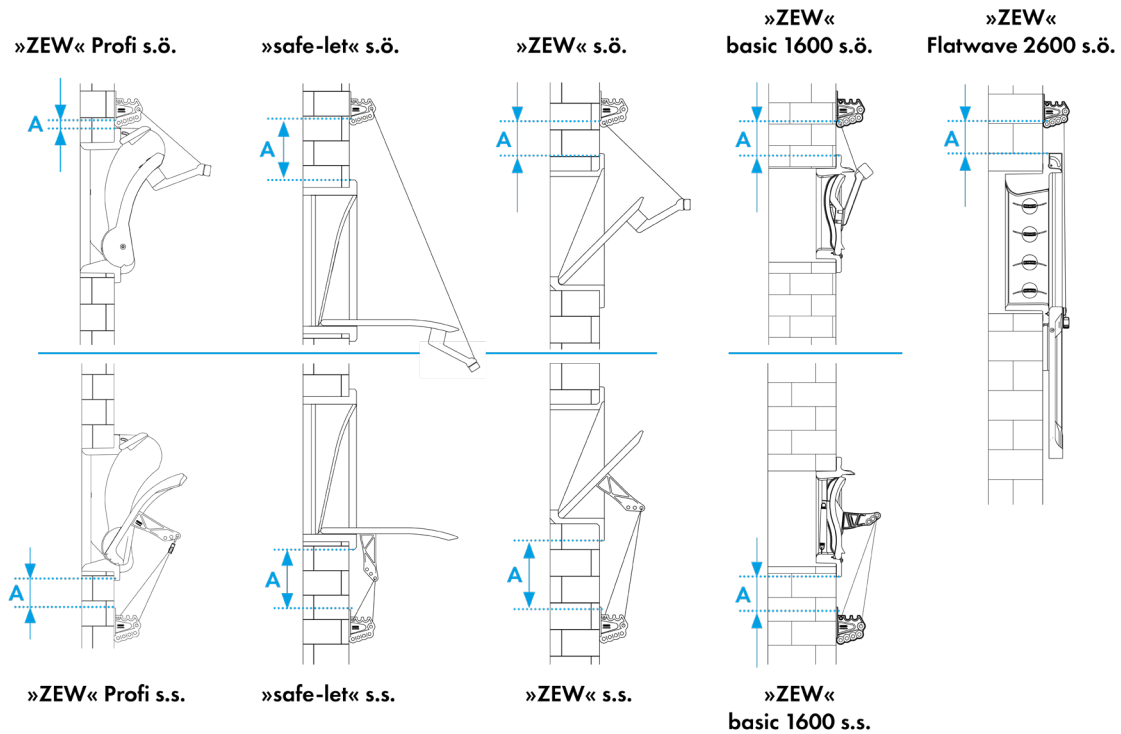

### Distances between wall guide / ceiling guide and fresh air inlets

Type	Distance A (minimum)		
	a.o. with wall guide	a.c. with wall guide	a.o. with ceiling guide
»ZEW« Professional 1300 / 2100	100 mm	100 mm	–
»ZEW« Professional 2900	200 mm	100 mm	–
»safe-let«	200 mm	200 mm	–
»ZEW« basic 1600	100 mm	100 mm	–
»ZEW« Flatwave 2600	100 mm	–	–
»ZEW«	100 mm	200 mm	–
»ZED« Professional 1800	–	–	100 mm
»ZED« 1800	–	–	100 mm
»ZED« 1000 / 1500	–	–	100 mm

## 3 »ZEW« Flatwave 2600 a.o.

### 3.1 Introduction

The wall air inlet regulates the supply air stream into livestock sheds. It is opened automatically in this model:

- Automatic opening (a.o.): The force of gravity opens the fresh air inlet and a pull rope is used to close it.

### 3.2 Technical data

Type	Item code	Air flow (m <sup>3</sup> /h)	Tensile force (N)	Stroke path (mm)	W x H x D (mm)	Weight (kg)
»ZEW« Flatwave 2600 automatic opening (a.o.)	202260000	3,750*	40	430	741 x 698 x 182	6.6
»ZEW« Flatwave automatic opening (a.o.), including bird protective grid	202260100	3,750*	40	430	741 x 698 x 182	6.6

\* Flow rate in m<sup>3</sup>/h at 20 Pa

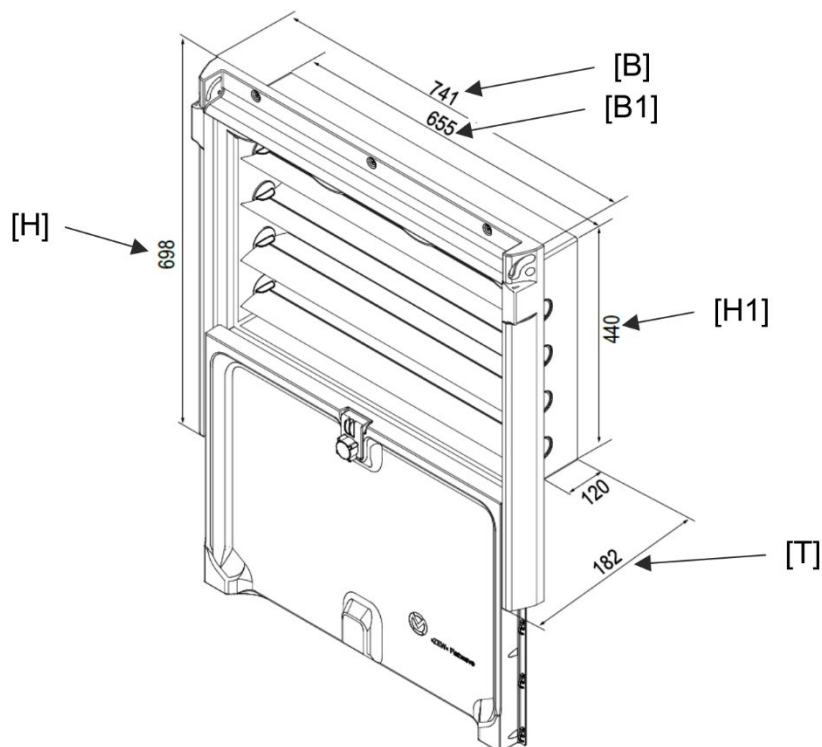

### 3.3 Mounting overview

Work steps »ZEW« Flatwave a.o.

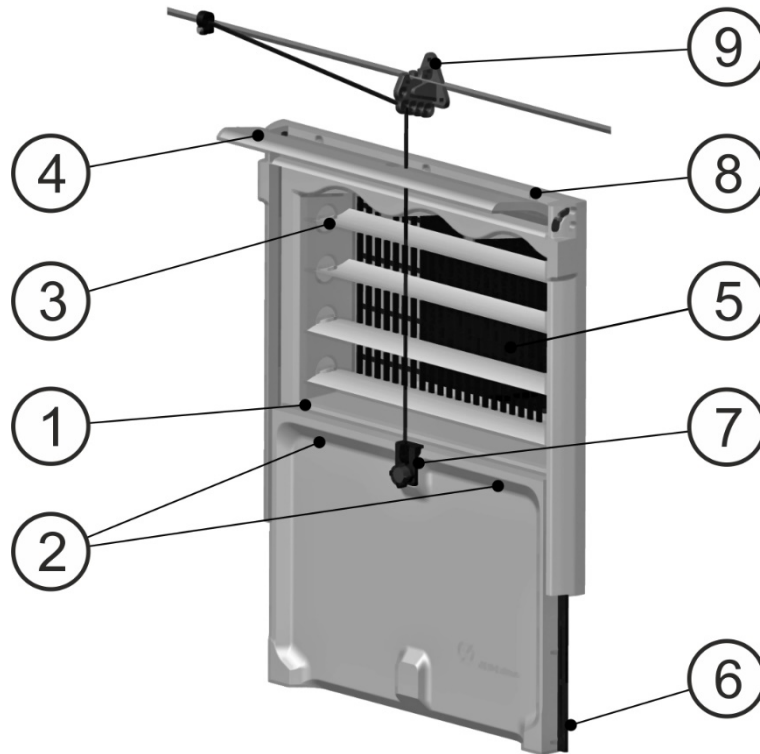

**PLEASE NOTE!**

Use a torque of < 2 Nm to tighten screws which are fastened into PU foam parts or screwed into place with PU foam parts.

Work step	Tools and material	Description
<p>1</p>	1x frame 1x seal	Press seal into the groove
<p>2</p> <p>[A]</p>	2x flap holders 2x chipboard screws, 3.5 x 25, countersunk head, partial thread	Position flap holders: 30 mm distance from the rail. Fasten onto the centre of the frame with a screw. Flap holder must not collide with the flap or the shed wall. Carry out work step on left and right.

[A] = 30 mm

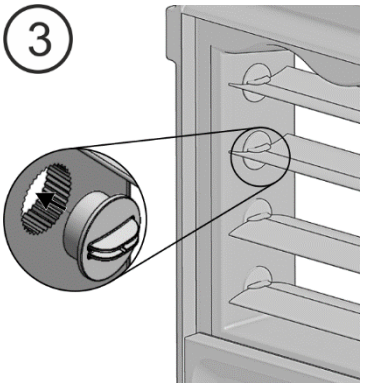
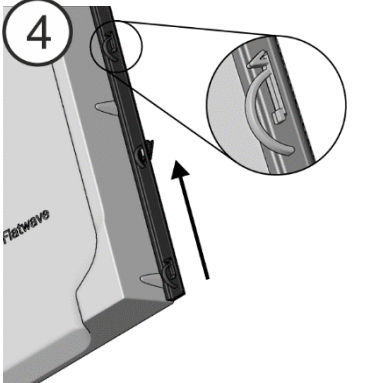
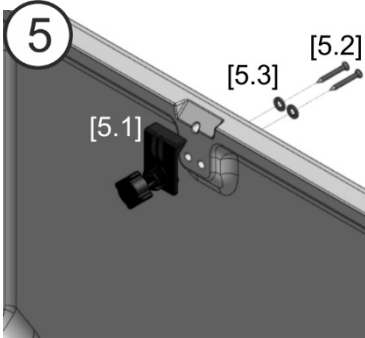
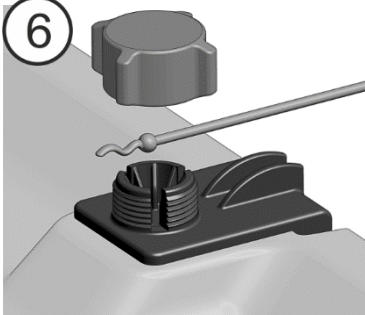
Work step	Tools and material	Description
 <p>3</p>	<p>8x Flatwave air conduction profile cap                      4x Flatwave air conduction profile</p>	<p>Position air conduction profile cap on both sides and insert into the openings.                      Bend air conduction profile slightly and insert into the air conduction profile cap mounts. Position upper and lower air conduction profiles as shown in the diagram.</p>
 <p>4</p>	<p>1x flap                      10x spring mechanisms</p>	<p>Position spring mechanism. Observe the flap's direction of closing (see arrow).                      Insert spring mechanisms into the rail from below. Take into account direction of installation.                      Carry out work step on left and right.                      Check all spring mechanisms are firmly locked into the correct position.</p>
 <p>5</p>	<p>1x [5.1] flap holder                      1x nut for flap holder                      2x [5.2] chipboard screws, 5 x 45, countersunk head                      2x [5.3] washer 8.4 x 17</p>	<p>Position flap holder on flap.                      Place washer on screw.                      Fasten flap holder into position with screw.                      Carry out work step on left and right.</p>
 <p>6</p>	<p>1x cord</p>	<p>Knot the end of the cord.                      Place knot in flap holder.                      Bolt with nut.</p>

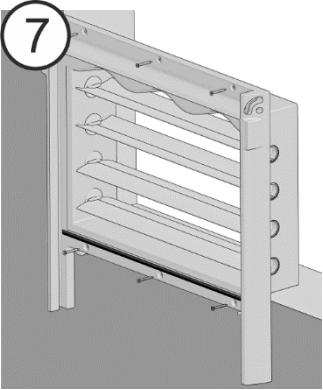
Work step	Tools and material	Description
	<p>1x »ZEW« Flatwave fitted                      6x screws and dowels, not included in scope of supply</p>	<p>Install »ZEW« Flatwave on the shed wall.                      Fasten »ZEW« Flatwave into position at all marked points.                      Observe instructions on supply components.</p>

**Optional work steps »ZEW« Flatwave a.o.**

<p><b>PLEASE NOTE!</b></p>	<p>Use a torque of &lt; 2 Nm to fasten screws.                      Step 8 and Step 9 are completed before the frame is mounted into the shed wall.</p>
----------------------------	---

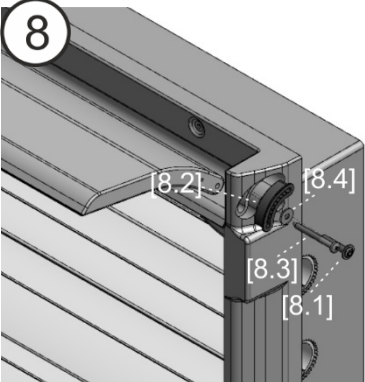
Work step	Tools and material	Description
	<p>Optional                      1x air conduction profile                      2x [8.1] ULF screw M6 x 30                      2x [8.2] air conduction profile mount                      2x [8.4] washer 5.3 x 15                      2x [8.3] chipboard screw, 5 x 50, fillister head, partial thread.</p>	<p>Position optional air conduction profile in frame.                      Fasten into position with screw [8.1].                      Insert mount into frame.                      Place washer on screw [8.4].                      Insert stop [8.2] into the slot, push screw [8.3] through mount and screw it to the air conduction profile. Do not fasten completely.                      Carry out work step on left and right.</p>

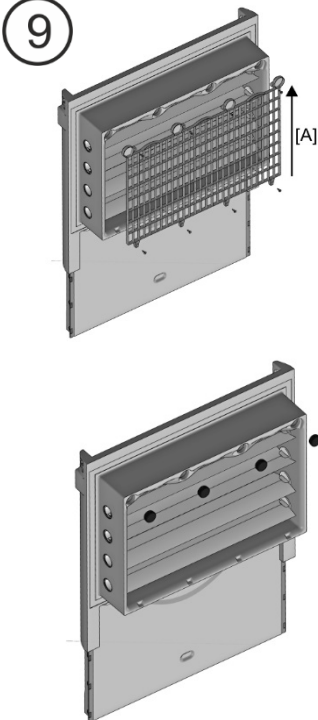
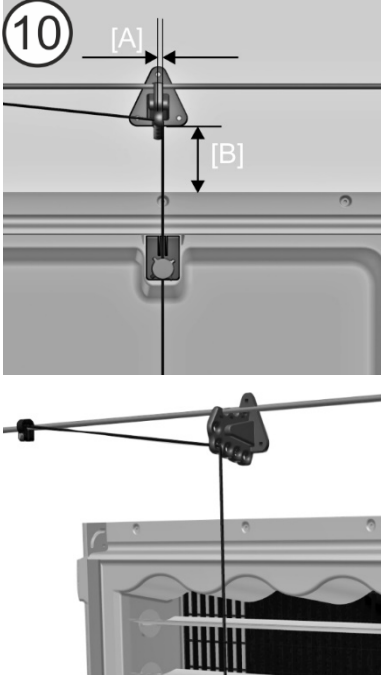
Work step	Tools and material	Description
<p>9</p> 	<p><b>with bird protective grid (optional)</b></p> <p>1x bird protective grid              8x chipboard screws, 4 x 16, countersunk head</p> <hr/> <p>[A] = direction of installation</p> <p><b>without bird protective grid (optional)</b></p> <p>4x plugs</p>	<p>Position optional bird protective grid. Fit curves on the bird protective grid into curves in the frame.</p> <p>Insert and centre bird protective grid into the frame pockets.</p> <p>Fasten into position with screws</p> <hr/> <p>Insert plugs into the frame pockets.</p>
<p>10</p> 	<p>Optional</p> <p>1x wall guide – not included in the scope of supply</p> <hr/> <p>[A] = 6.5 mm              [B] = min. 100 mm</p>	<p>Fit wall guide:</p> <p>Distances:              Top drill hole perpendicular to the cord 6.5 mm.</p> <p>Pull rod or pull rope to the lower edge of the wall guide at least 100 mm.</p> <p><b>Note:</b></p> <p>Thread cord through the foremost hole of the wall guide so that the cord runs vertically.</p>



### 3.4 Finishing work

Separate and dispose of the packaging material as per statutory requirements.

### 3.5 Accessories (optional)

Article	»ZEW« Flatwave 2600
Wall guide	Item no. 9-201990800
Bird protective grid	Article no. 202260790
Air guide plate 180 mm	Article no. 202260008
Wind deflection hood	Article no. 209219910
Wind deflection hood, including light filter	Article no. 209219902
Light filter	Item no. LF05190760

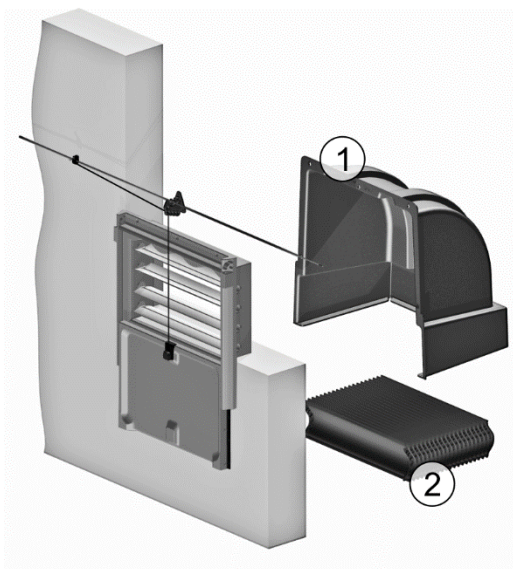

Image Variant with accessories: Wind deflection hood and light filter

1+ 2 wind deflection hood including light filter

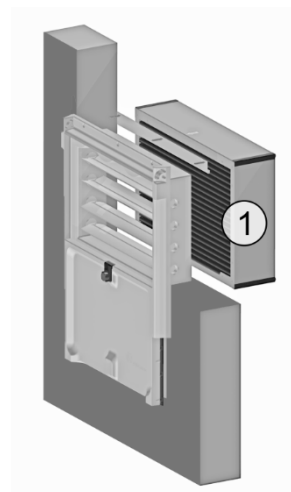

Image Variant with accessories: Light filter

1 light filter