

Installation and User Manual

CommBox for GreenField App



CommBox for GreenField App

Internet Access to Controllers

Ag/MIS/UmGb-2833-01/22 Rev 1.8

P/N: 116865



CommBox for GreenField App

Installation and User Manual

Rev 1.8, 12/2023

Software Ver: 4.6.0.35

This manual for use and maintenance is an integral part of the apparatus together with the attached technical documentation.

This document is destined for the user of the apparatus: it may not be reproduced in whole or in part, committed to computer memory as a file or delivered to third parties without the prior authorization of the assembler of the system.

Munters reserves the right to effect modifications to the apparatus in accordance with technical and legal developments.

Index

<i>chapter</i>		<i>page</i>
1	INTRODUCTION	5
1.1	Disclaimer.....	5
1.2	Introduction	5
1.3	Notes	5
2	INTRODUCTION TO THE COMMBOX.....	6
2.1	Junction Box.....	6
2.2	What Comes in the Package.....	6
2.3	Supported Devices	6
3	HARDWARE INSTALLATION	7
3.1	CommBox Ports.....	7
3.2	Mounting the CommBox.....	8
3.3	Grounding	8
3.4	Connecting the CommBox to the Internet	9
3.5	Connecting the CommBox to Peripheral Devices	9
3.6	Connecting the CommBox to a Controller	10
3.6.1	Controller to Junction Box Wiring	10
3.6.2	RLINK One to Junction Box Wiring	12
3.6.3	CommBox to Junction Box Wiring	13
3.6.4	Wiring Topology.....	16
3.6.5	Termination	17
3.6.5.1	Termination Topologies	17
3.6.5.2	Termination Wiring.....	17
4	TECHNICAL DATA	18
4.1	CommBox.....	18
4.2	Junction Box.....	19
5	GROUP MANAGEMENT	20
5.1	What is a Group	20
5.2	Activating the Farm.....	21
5.3	Invite Users	26
5.3.1	Sending an Invitation.....	26
5.3.2	Defining User Privileges.....	27
5.4	Local Log In.....	28
6	ROTEMNET WEB.....	29

6.1	Sign In.....	29
6.1.1	Standard Login.....	29
6.1.2	Private Server.....	30
6.2	My Farm Groups.....	31
6.2.1	Details (Optional).....	31
6.2.2	Users.....	32
6.2.2.1	Existing Users.....	32
6.2.2.2	New Users.....	32
6.2.3	Farms.....	34
6.2.4	Manage Groups.....	34
6.2.5	User Settings.....	35
6.3	RotemNet Farm Management.....	36
6.3.1	Dashboard.....	36
6.3.2	RotemNet Screen Appearance.....	37
6.4	RotemNet Web Functionality.....	38
6.4.1	Farm Settings Tab.....	38
6.4.1.1	Farm Settings.....	39
6.4.1.2	External Devices.....	40
6.4.1.3	Push Notifications.....	40
6.4.1.4	Local Users.....	40
6.4.1.5	Data Collect.....	41
6.4.1.6	Activity Log.....	41
6.4.2	House Scan Tab.....	41
6.4.3	Diagnostics Tab.....	43
6.5	Software Upgrade.....	45
6.6	About Tab.....	46
7	APPENDIX A: GENERATING AN ACTIVITY LOG.....	47
8	APPENDIX B: DATA COLLECTION.....	49
8.1	Centralized Collection.....	49
8.2	Defining the FTP/SFTP server.....	51
9	WARRANTY.....	53

1 Introduction

1.1 Disclaimer

Munters reserves the right to make alterations to specifications, quantities, dimensions etc. for production or other reasons, subsequent to publication. The information contained herein has been prepared by qualified experts within Munters. While we believe the information is accurate and complete, we make no warranty or representation for any particular purposes. The information is offered in good faith and with the understanding that any use of the units or accessories in breach of the directions and warnings in this document is at the sole discretion and risk of the user.

1.2 Introduction

Congratulations on your excellent choice of using the CommBox Communication Device!

In order to realize the full benefit from this product it is important that it is installed, commissioned and operated correctly. Before installation or using the device, this manual should be studied carefully. It is also recommended that it is kept safely for future reference. The manual is intended as a reference for installation, commissioning and day-to-day operation of the Munters equipment.

1.3 Notes

Date of release: July 2019

Munters cannot guarantee to inform users about the changes or to distribute new manuals to them.

All rights reserved. No part of this manual may be reproduced in any manner whatsoever without the expressed written permission of Munters. The contents of this manual are subject to change without notice.

2 Introduction to the CommBox

NOTE This manual details how to set up and run the CommBox. The controllers' software programs are documented in separate manuals.

CommBox provides complete access to your Munters irrigation controllers, including monitoring and control capabilities (GreenField App), from any device, anywhere. From one computer, tablet, or smartphone, you can manage an entire network.

- Cloud-based access to controllers
 - Multiple, simultaneous users have network access
- Multiple communication pathways
 - Built-in internet and telephone connectivity
 - Cellular connectivity option
 - 960-13-10001: COMMBOX-GRH-EN-MUR-JB485-WEB (no modem)
 - 960-13-10029:COMMBOX-GRH-EN-MUR-CMGB-JB485-WEB (includes global modem)
- Local communication via wired or wireless communication
- Status reports provide critical information on irrigation functions and statistics
- Push notifications

2.1 Junction Box

Connecting a CommBox directly to a controller requires a Junction Box. Refer to Connecting the CommBox to a Controller, page 10.

- P/N: 960-99-00091 COMMBOX-JUNCTION BOX RS485 (COMMBOX-JB-485)

2.2 What Comes in the Package

- CommBox
- Junction Box
- Power Supply Cables 115VAC and 230VAC

2.3 Supported Devices

- The following product versions support the Greenfield App application:
 - Greenfield Version 3.08.05 and above.
 - Greenfield Eco Version 9.08.05 and above.

NOTE Before upgrading the Greenfield from Version 3.07.XX to 3.08.XX the first time, copy (photograph) the settings of the controllers' tables. These tables can't be uploaded from a data plug; they must be entered manually.

3 Hardware Installation

This document details how to install Munters' CommBox unit. Installation consists of:

- CommBox Ports
- Mounting the CommBox
- Grounding
- Connecting the CommBox to the Internet
- Connecting the CommBox to Peripheral Devices
- Connecting the CommBox to a Controller

NOTE No software installation is required.

3.1 CommBox Ports

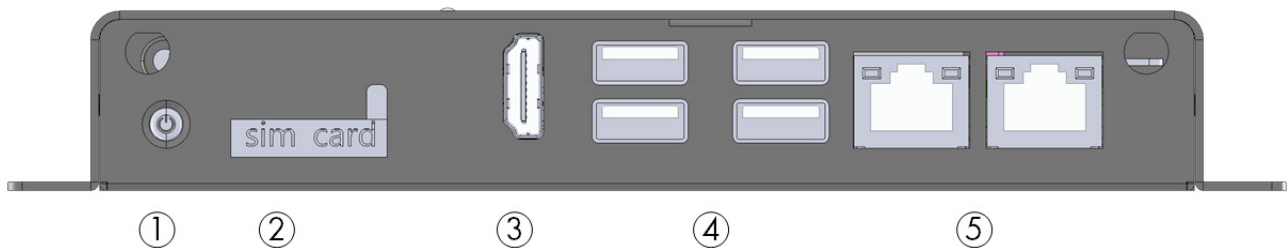

Figure 1: Front View

Number	Description
1	On/off button
2	SIM Card port (4G card can be used with a modem for cellular connectivity)
3	HDMI port (refer to Connecting the CommBox to Peripheral Devices)
4	USB ports(refer to Connecting the CommBox to Peripheral Devices)
5	Internet ports (refer to Connecting the CommBox to the Internet)

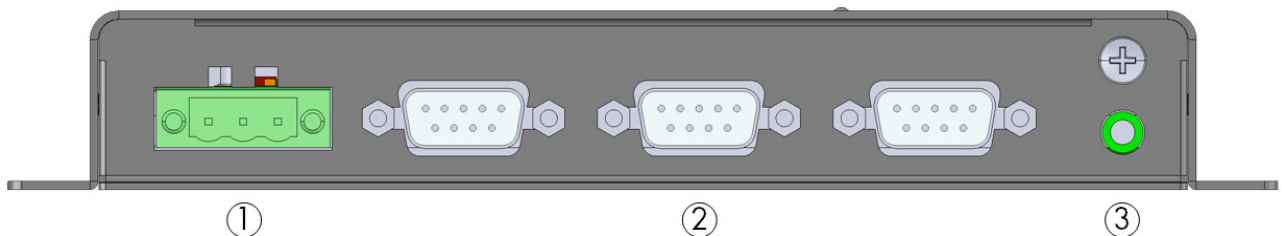

Figure 2: Rear View

Number	Description
1 & 2	External box cable connectors
3	Audio out

3.2 Mounting the CommBox

- Using the screws provided, mount the unit.

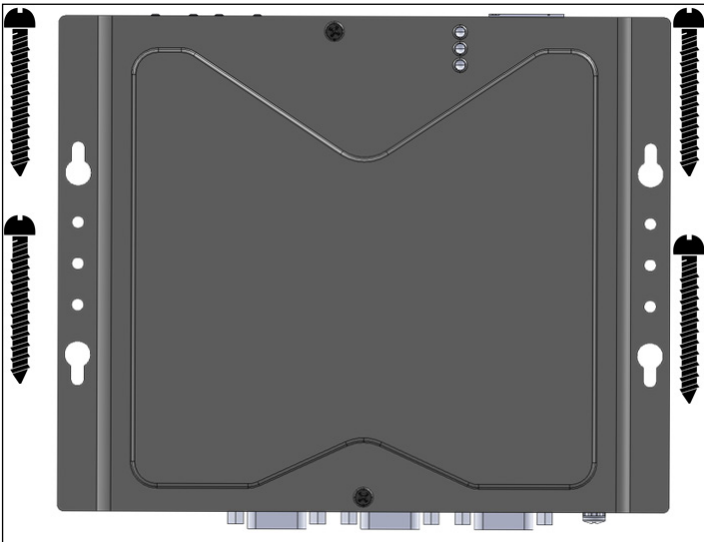

Figure 3: Unit and Mounting Screws

3.3 Grounding

- Connect the ground cable to the dedicated ground terminal.

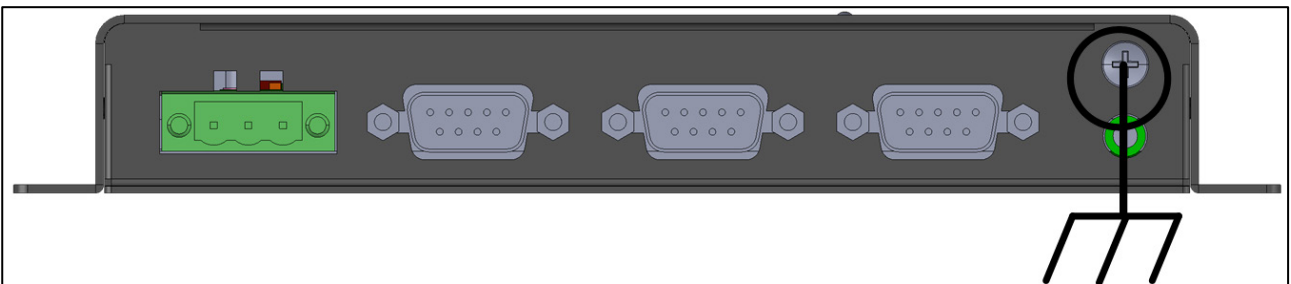

Figure 4: Grounding Schematic

CAUTION The CommBox must be grounded at all times!

3.4 Connecting the CommBox to the Internet

- Connect the CommBox to your Internet connection/modem.

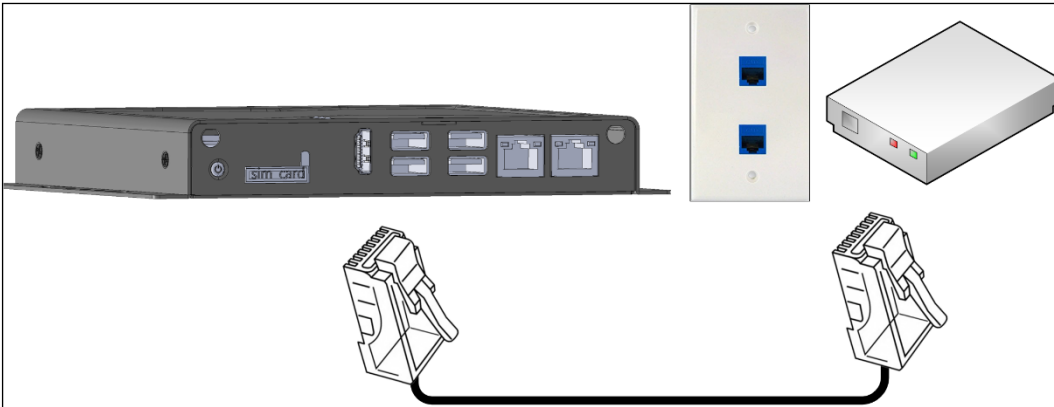

Figure 5: Internet Connection

3.5 Connecting the CommBox to Peripheral Devices

When required, connect a screen, keyboard, or mouse to the CommBox (via the USB/HDMI ports).

NOTE Connect the screen to the CommBox using an HDMI cable only. Do not use any other type of cable connected to an HDMI adapter.



Figure 6: Peripheral Devices

3.6 Connecting the CommBox to a Controller

The only step in installing a CommBox that requires wiring is if the CommBox is connected directly to a controller (instead of to a communication unit). In this situation the CommBox must be wired to the controller communication card via a Junction Box.

- Controller to Junction Box Wiring
- RLINK One to Junction Box Wiring
- CommBox to Junction Box Wiring
- Wiring Topology
- Termination

WARNING! *Disconnect the power before beginning!*

WARNING! *Only an authorized electrical technician may perform this procedure!*

3.6.1 CONTROLLER TO JUNCTION BOX WIRING

In the controller, connect the CommBox to the controller's communication card, via the Junction Box. Refer to the following illustrations.

NOTE *GreenField irrigation installation supports RS-485 wiring only.*

1. The cable between the controller and the Junction Box should be a 3-wire twisted shielded cable (22 or 24 AWG).
2. Connect the wiring as follows:
 - COM to COM
 - CommBox A port is connected to Controller's A port.
 - The CommBox B port is connected to Controller's B port.
3. The final controller in any chain or branch requires a 120-ohm terminator.
4. Connect the cable shield wire to the controller ground strip.

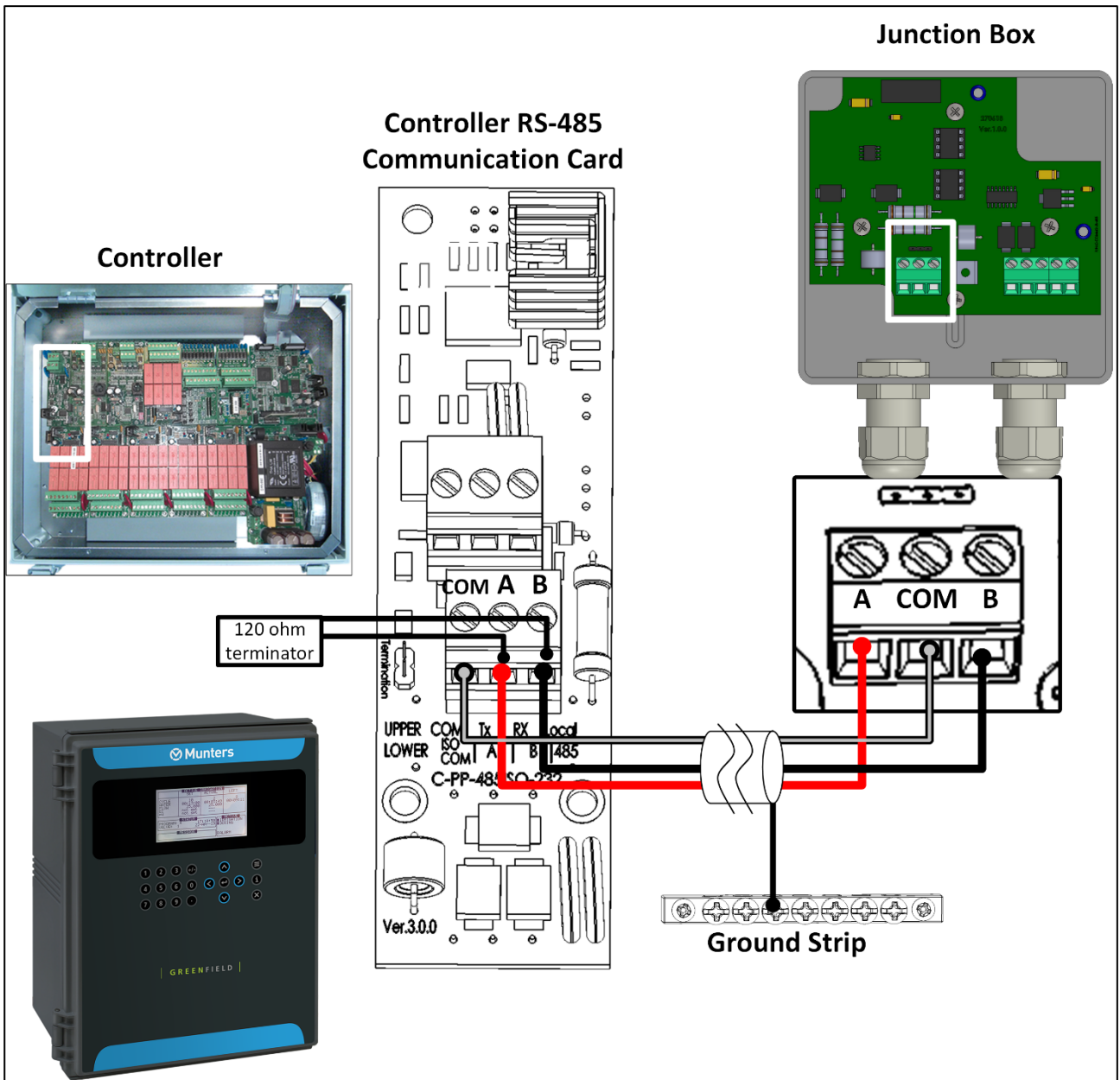

Figure 7: Green Field RS-485 Wiring

CAUTION Connect one end of the cable's shield only (the other end must be open). Each controller should be chain connected to the same wire, resulting in a long ground cable without a ground loop.

3.6.2 RLINK ONE TO JUNCTION BOX WIRING

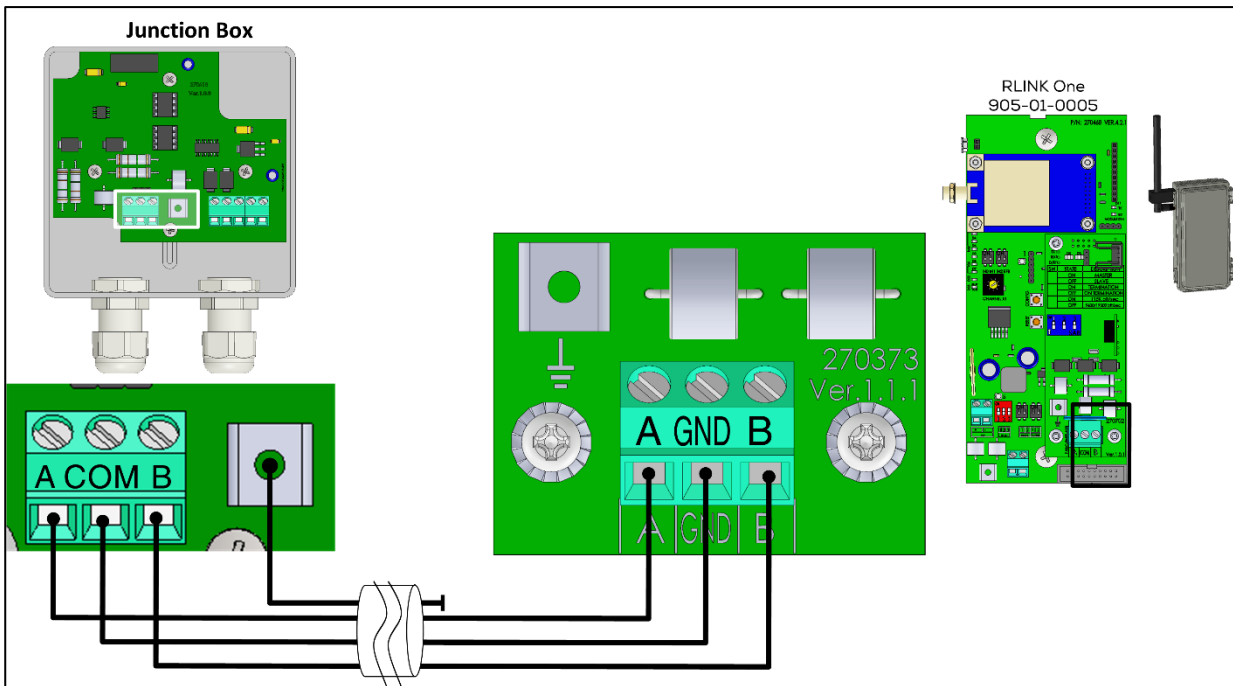

Figure 8: RLINK One RS-485 Wiring

1. The cable between the external connection box and the RLINK One should be a 3-wire twisted shielded cable (22 or 24 AWG).
2. Connect the wiring as follows:
 - COM to COM
 - CommBox A port is connected to Controller's A port.
 - The CommBox B port is connected to Controller's B port.
3. The final controller in any chain or branch requires a 120-ohm terminator. Refer to Termination, page 17.
4. Connect the cable shield wire to the controller ground strip.

3.6.3 COMMBOX TO JUNCTION BOX WIRING

- The CommBox comes with the power supply wired to the unit. See Figure 9.

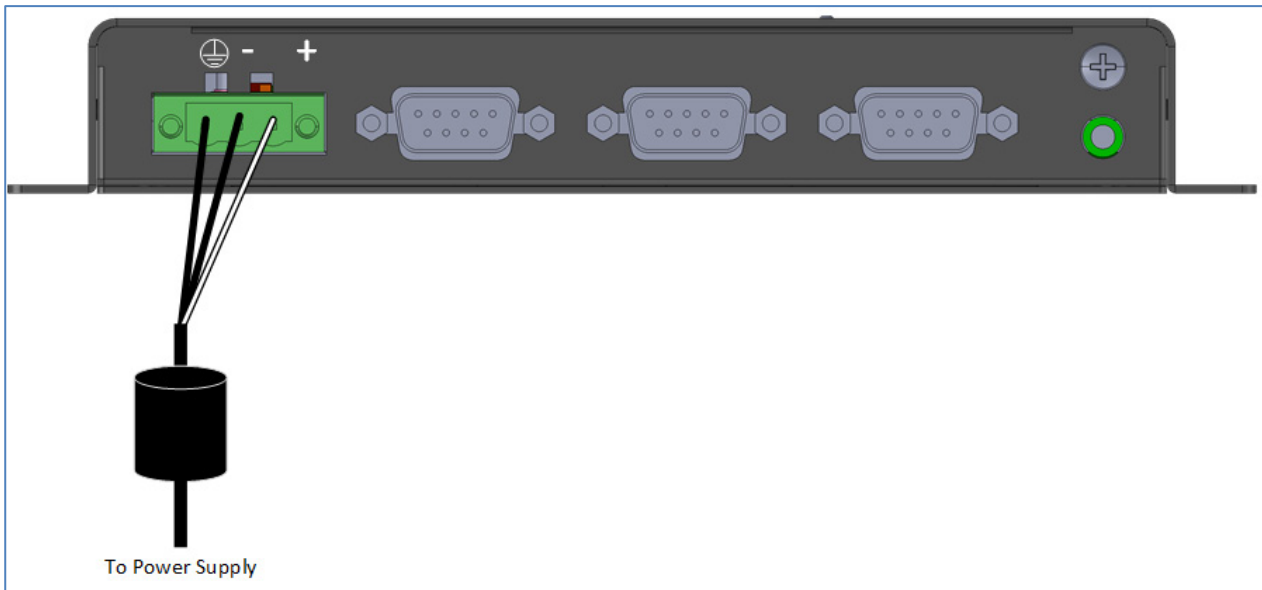

Figure 9: CommBox Power Supply Wiring

1. Insert the Junction Box 9-Pin Connector into COM1 (see Figure 10).

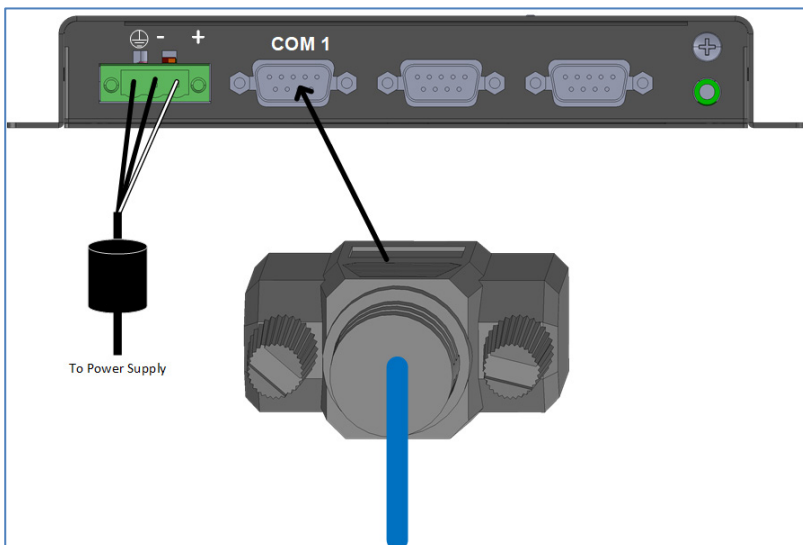

Figure 10: Insert 9 Pin Connector

2. Insert the two wires coming from the Junction Box cable into the ports (see Figure 11 and Figure 12).

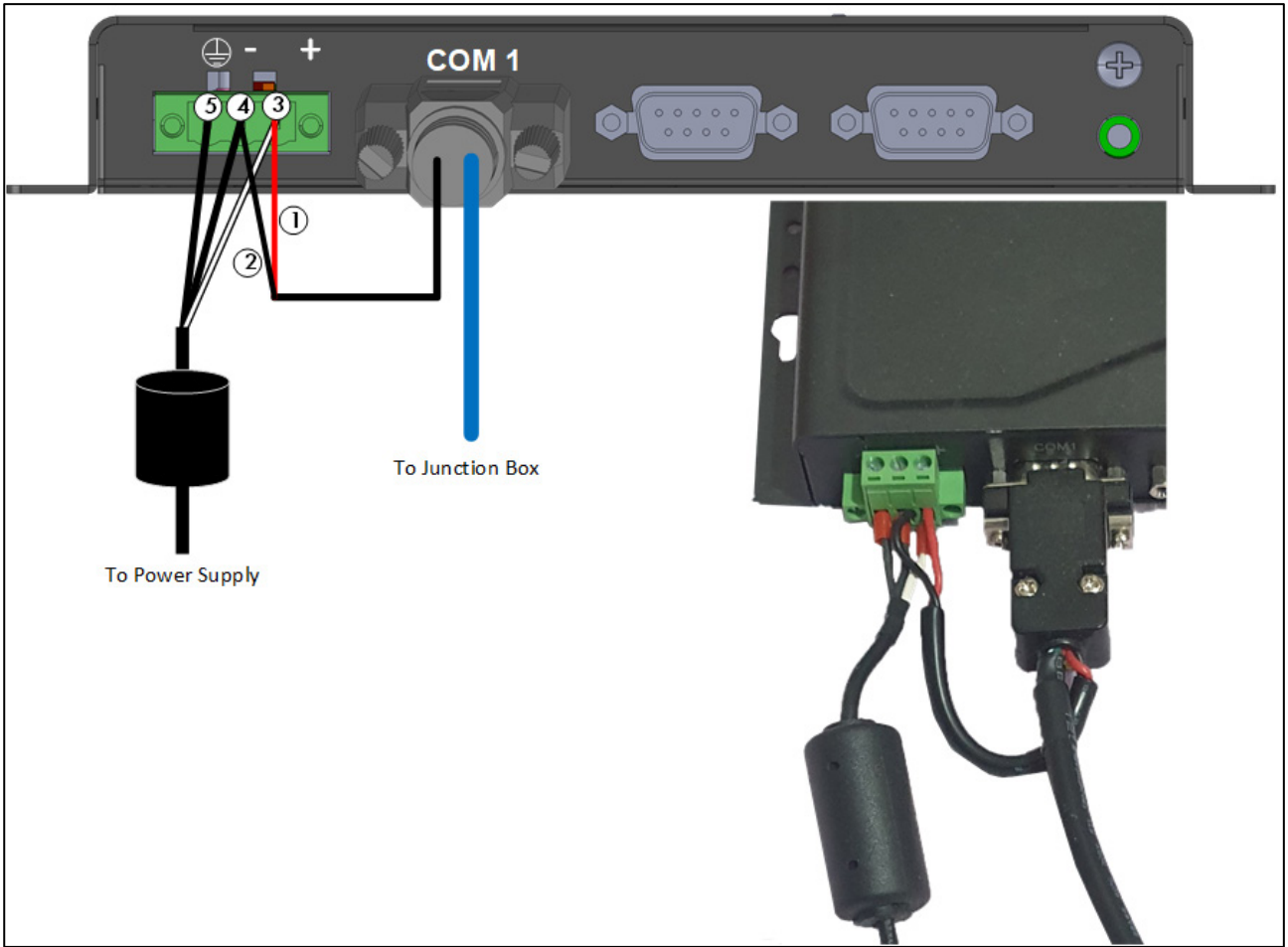

Figure 11: Junction Box Wiring to CommBox

Table 1: Wiring Details

Cable source	Color	Function	Number
Junction Box Cable	Red	+VCC (24 DC)	1
	Black	-VCC (Junction Box)	2
Power Supply Cable*	White	+VCC (Junction Box) (24 DC)	3
	Black	-VCC	4
	Black	Ground	5

*These wires come preconnected to the CommBox. If they need to be reattached, place the white cable (#3) in the port as shown in Figure 4. Place both black cables into the ports as shown in Figure 4; either cable can be placed in either port.

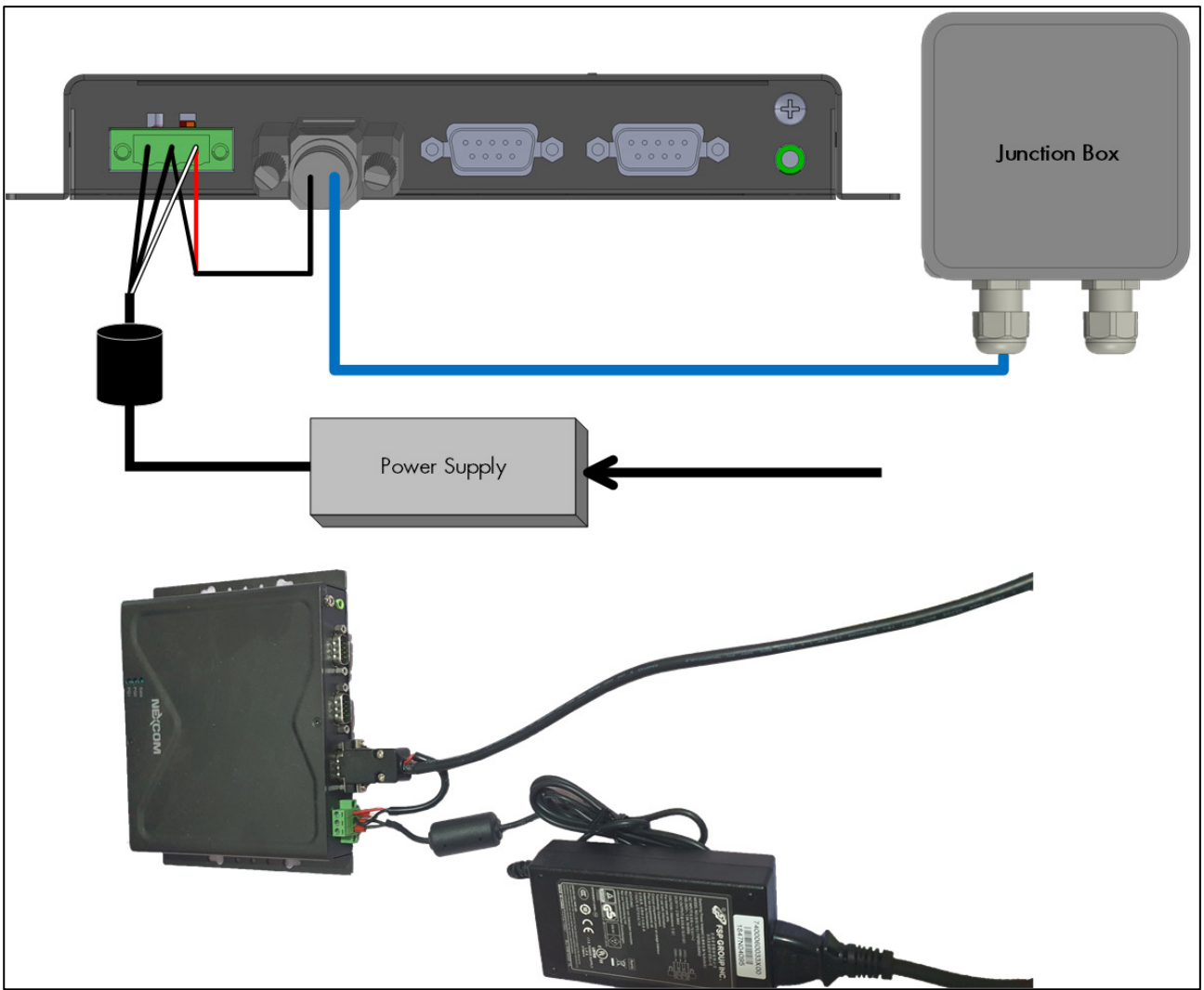

Figure 12: Power Supply – CommBox – Junction Box Setup

3.6.4 WIRING TOPOLOGY

When connecting the CommBox to controllers via an RS-485 infrastructure, use one of the following allowed topologies to ensure signal integrity.

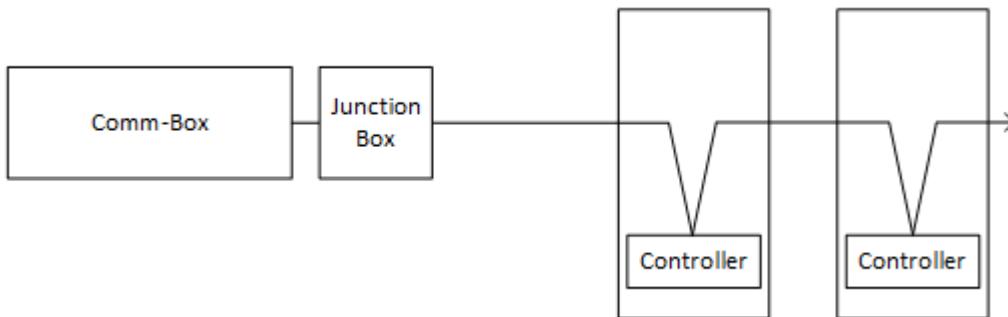

Figure 13: Direct connections

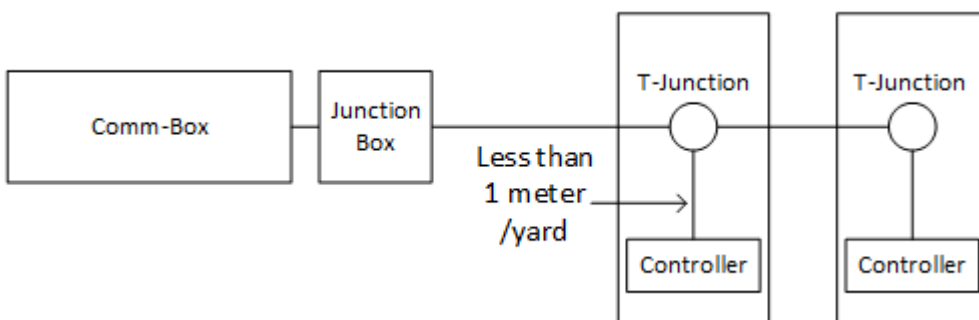

Figure 14: T-Junction (permitted)

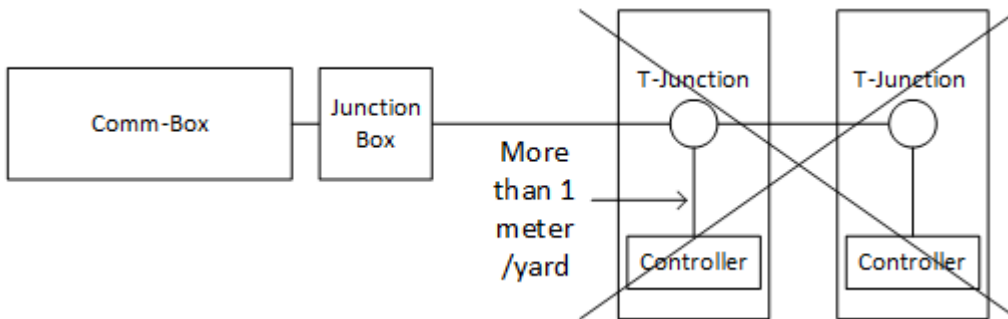

Figure 15: T-Junction (not permitted)

3.6.5 TERMINATION

Termination, installing 120-ohm termination resistors at the beginning and end units of each chain of CommBox and controllers, ensures reliable communication in RS-485 infrastructures. The following illustrations show where to install the resistors. Depending on the topology, install the resistors in the T-box, the terminal controller, or the Munters Repeater.

Termination is recommended when the distance between the Junction Box and the final controller is more than 50 meters/165 feet. Munters Junction Box is supplied with a jumper and a 120 ohm resistor that can be installed in those installations (the jumper is placed in the Junction Box (see Figure 18, page 17), the resistor is installed in the controller).

Termination may not be required in shorter installations.

- Termination Topologies
- Termination Wiring

3.6.5.1 Termination Topologies

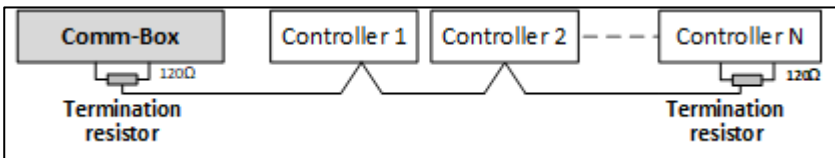

Figure 16: Topology 1: CommBox/Controller Termination

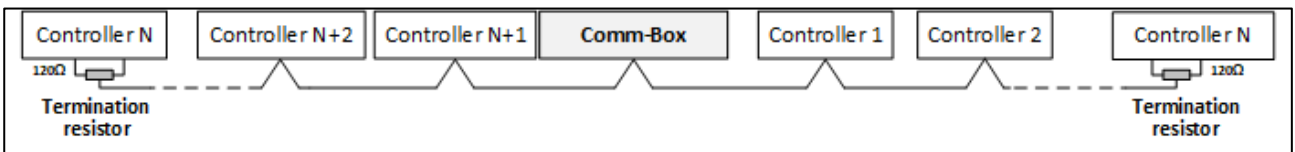

Figure 17: Topology 2: Controller Termination

3.6.5.2 Termination Wiring

- CommBox: Install the termination resistor in the Junction Box.

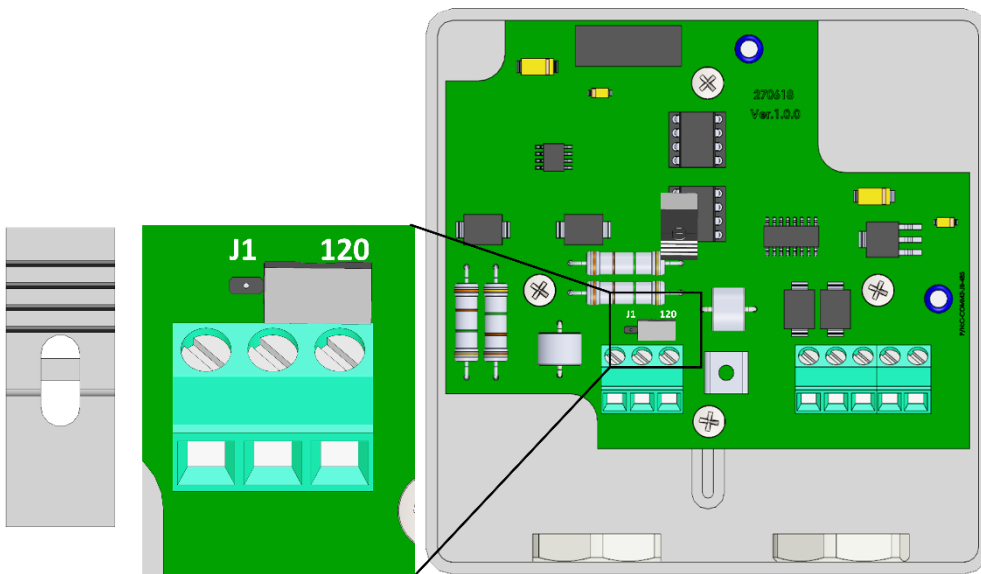





Figure 18: Junction Termination

4 Technical Data

4.1 CommBox

Power Supply	
Power Input	<ul style="list-style-type: none"> • 24V DC +/-20% • 1 x 24V, 60W power adapter
CAUTION Unit should be powered by Limited Energy Source per IEC 61010-1 or Limited Power Source per IEC 60950-1 or IEC 62368-1	
Temperature Range	
Operating Temperature Range	0° to +50° C / 32° to 125° F
Storage Temperature Range	-10° to +70° C / 14° to 158° F
Environmental Specifications	
<ul style="list-style-type: none"> • Indoor use only • Altitude: -400 m to 2000 m • Relative Humidity: 0 – 95% • Main supply voltage fluctuation up to 5% • Overvoltage category: OVCII • Pollution degree: PD2 • Ingress Protection: IPX0 	
Housing	
Metal Box Dimensions (W x H x D)	162 x 26 x 150 mm (without wall-mount bracket)
SIM Card Requirements	
Celphone SIM Card	4G
Cell Package	10 GB minimum
Certification	
  	

4.2 Junction Box

Power Supply	
Junction Box Power Input	24 VDC, 30 mA
CAUTION Unit should be powered by Limited Energy Source per IEC 61010-1 or Limited Power Source per IEC 60950-1 or IEC 62368-1	
Temperature Range	
Operating Temperature Range	0 ° to +45 ° C / 32 ° to 113 ° F
Storage Temperature Range	-10 ° to +70 ° C / 14 ° to 158 ° F
Environmental Specifications	
<ul style="list-style-type: none">• Indoor use only• Altitude: -400 m to 2000 m• Relative Humidity: 0 – 90%• Main supply voltage fluctuation up to 5%• Overvoltage category: OVCII• Pollution degree: PD2• Ingress Protection: IP50	

5 Group Management

When using the CommBox to connect to your farm(s), you must:

- [create \(activate\) a farm](#)
- [invites users](#)

5.1 What is a Group

A group is the virtual device used to manage your farms. Using the RotemNet Web application, the group manager defines each user's permissions (which farms he can see and what functions he can carry out).

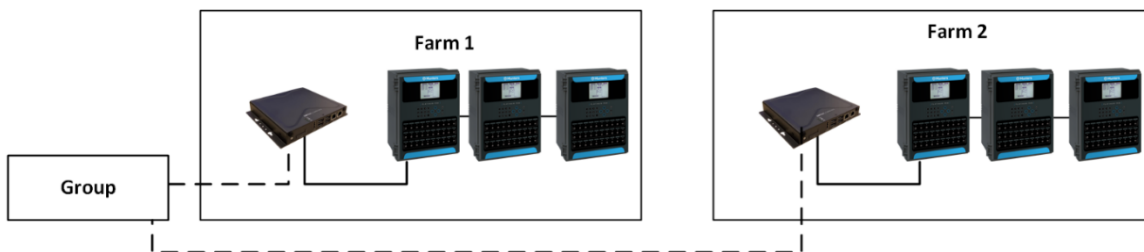

Figure 19: Group Example

As an example, an account manager has sent up two Groups and wants to add three different users to his account (Figure 20).

1. User 1 is assigned access rights to Farm 1.
2. User 2 is assigned access rights to Farm 2.
3. User 3 is assigned access rights to Farm 1 and Farm 2.
4. In addition, User 1 is also assigned access rights to Farm 3, which is in an entirely different group.

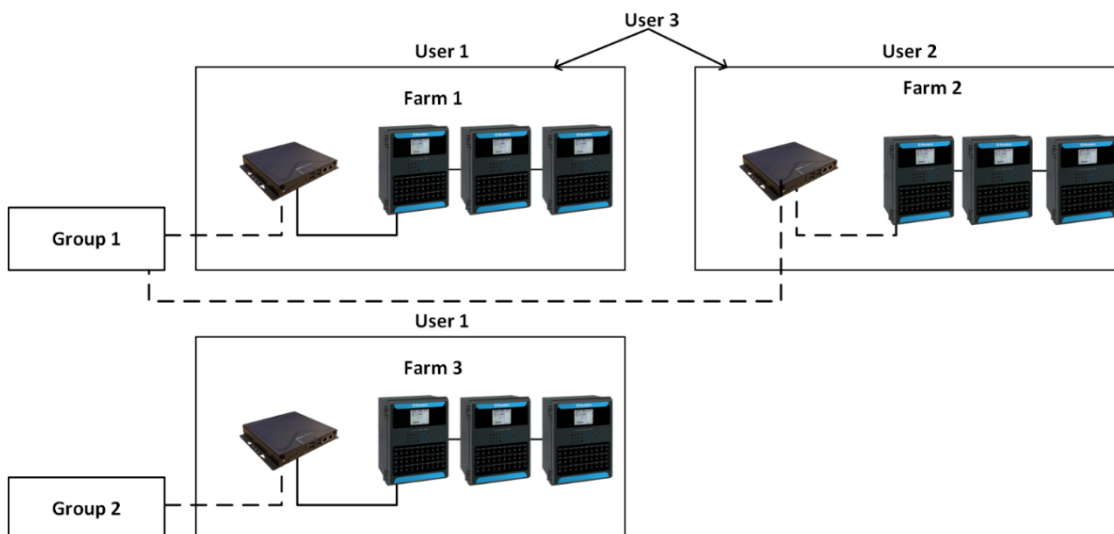

Figure 20: User Assignment

Any combination is possible.

5.2 Activating the Farm

The first time that you power up a CommBox, you need to activate a farm.

1. Connect the CommBox to a screen, keyboard, and mouse. Apply power. The Farm Activation screen appears.

House Number	House Name	House Number	House Name		
<input type="checkbox"/>	1	House 1	<input type="checkbox"/>	33	House 33
<input type="checkbox"/>	2	House 2	<input type="checkbox"/>	34	House 34
<input type="checkbox"/>	3	House 3	<input type="checkbox"/>	35	House 35
<input type="checkbox"/>	4	House 4	<input type="checkbox"/>	36	House 36
<input type="checkbox"/>	5	House 5	<input type="checkbox"/>	37	House 37
<input type="checkbox"/>	6	House 6	<input type="checkbox"/>	38	House 38
<input type="checkbox"/>	7	House 7	<input type="checkbox"/>	39	House 39
<input type="checkbox"/>	8	House 8	<input type="checkbox"/>	40	House 40
<input type="checkbox"/>	9	House 9	<input type="checkbox"/>	41	House 41
<input type="checkbox"/>	10	House 10	<input type="checkbox"/>	42	House 42
<input type="checkbox"/>	11	House 11	<input type="checkbox"/>	43	House 43
<input type="checkbox"/>	12	House 12	<input type="checkbox"/>	44	House 44
<input type="checkbox"/>	13	House 13	<input type="checkbox"/>	45	House 45
<input type="checkbox"/>	14	House 14	<input type="checkbox"/>	46	House 46
<input type="checkbox"/>	15	House 15	<input type="checkbox"/>	47	House 47
<input type="checkbox"/>	16	House 16	<input type="checkbox"/>	48	House 48

Figure 21: Activation Screen

2. Fill in the fields:

- Name: Type in the farm name.
- Farm Type: Choose the type from the drop-down list.
- Baud rate/Com Port: CommBox has a default setting of 9600 BPS, respectively. If you need to change this setting, click on the pencil and choose a setting from the drop-down list.
 - Verify that the CommBox and controller baud rates are the same.
 - The Com Port must be Com Port 1.
- Contact info: This is optional information which enables Munters to contact you if needed.

NOTE You can edit these settings in RotemNet Web.

- Mark the checkboxes of the houses to be scanned. Mark at least one house. As an option, the house names can be edited.

3. Click Activate. A pop up appears asking if you want to scan your farm houses.

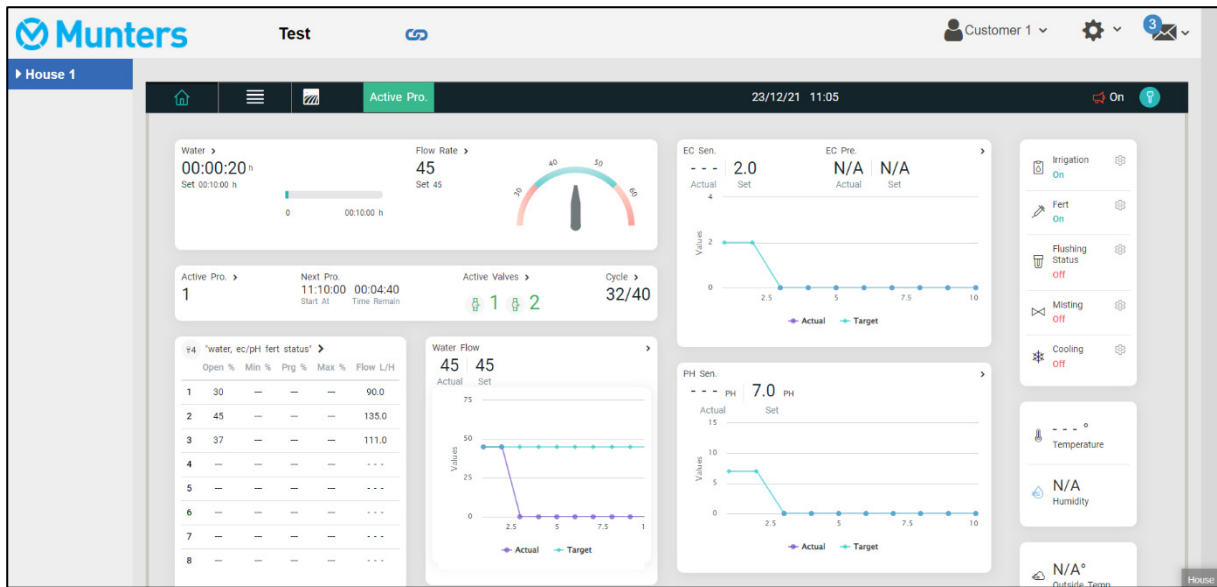
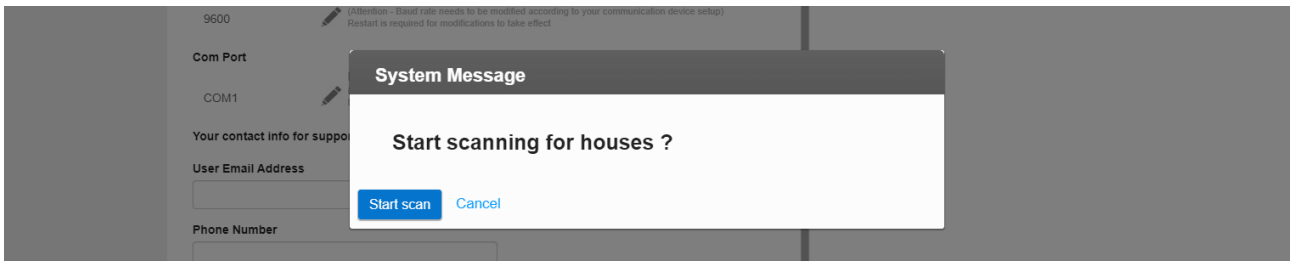

Figure 22: Green Field Dashboard

4. Click the settings icon () and go to farm settings. The following screen appears.

Figure 23: Initial Farm Settings Screen

5. Click Connect. The following screen appears.

Figure 24: Initial Sign In Form

6. From the drop down lists, select the region and language.

CAUTION If you are using the Irrigation application, select America only.

7. Click Sign Up Now. The following screen appears.

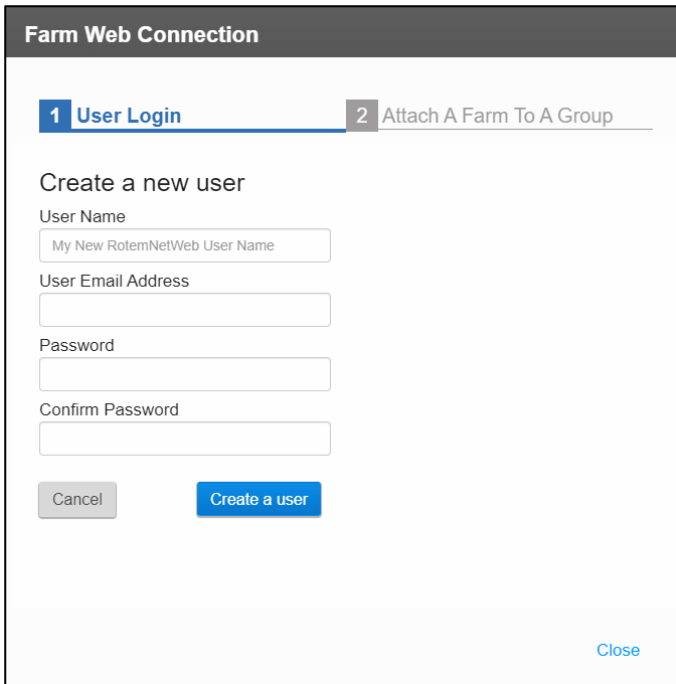

The screenshot shows a dialog box titled "Farm Web Connection" with a dark header. Below the header, there are two tabs: "1 User Login" (active) and "2 Attach A Farm To A Group". The "Create a new user" section contains four input fields: "User Name" (with placeholder text "My New RoleNetWeb User Name"), "User Email Address", "Password", and "Confirm Password". At the bottom left are "Cancel" and "Create a user" buttons. A "Close" link is at the bottom right.

Figure 25: Create a New User Screen

8. Fill in all fields and click Create a User.

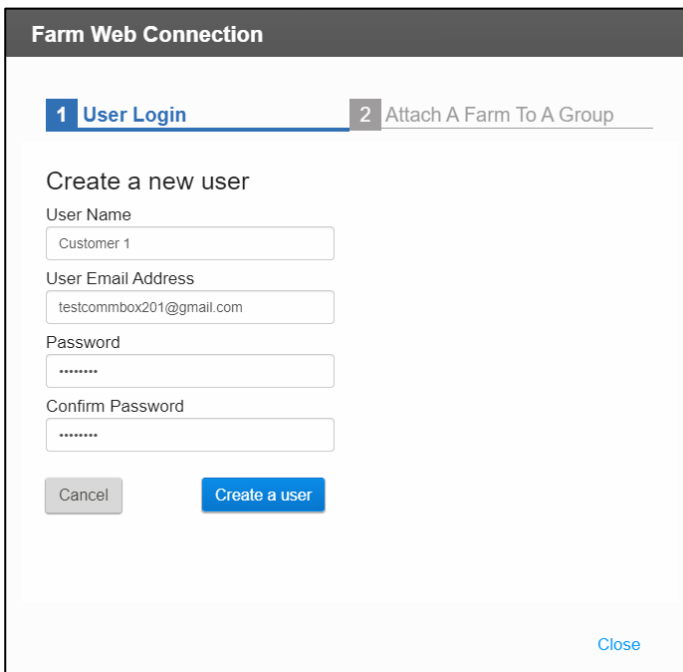

This screenshot is identical to Figure 25 but shows example data entered into the fields: "User Name" is "Customer 1", "User Email Address" is "testcommbox201@gmail.com", and both "Password" and "Confirm Password" are filled with seven asterisks. The "Create a user" button is highlighted in blue.

Figure 26: Create a User (Example)

9. Click Attach a Farm to A Group. The following screen appears:



Figure 27: Group Screen (1)

10. Write the name of the farm group that you want to create and click Attach to Group.

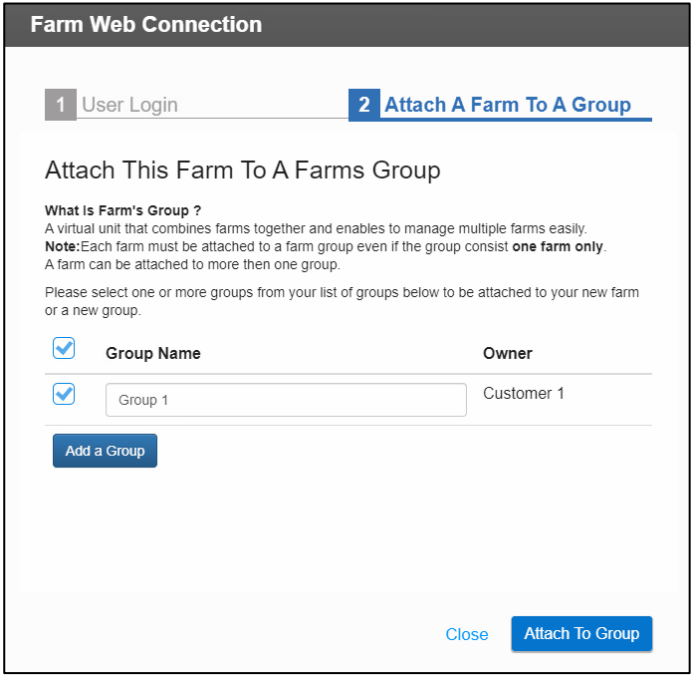

Figure 28: Farm Attached to Group

NOTE To create new groups, click Add a Group.

5.3 Invite Users

The following section details how to invite news users and define the user privileges.

- Sending an Invitation
- Defining User Privileges

5.3.1 SENDING AN INVITATION

1. The person to be invited must be registered in the system.
 - If the user has signed up to rotemnetweb.com, proceed to Step 2.
 - a. If the invitee is not registered in the system, go to <https://rotemnetweb.com/>.

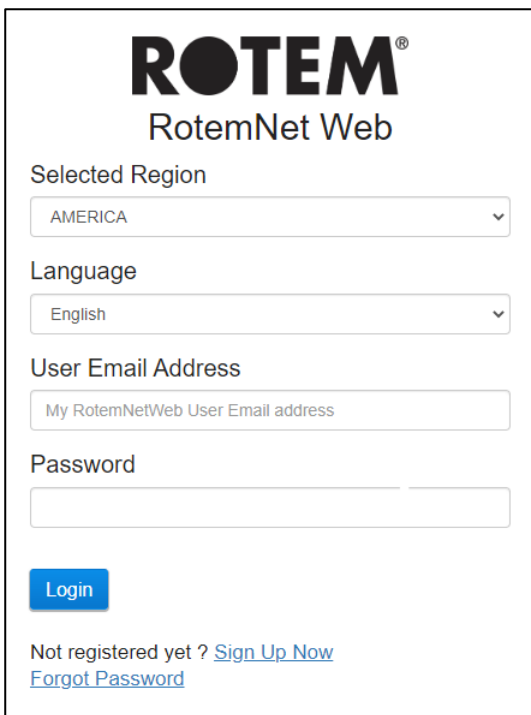

The screenshot shows the RotemNet Web login interface. At the top is the ROTEM logo and the text 'RotemNet Web'. Below this are two dropdown menus: 'Selected Region' with 'AMERICA' selected and 'Language' with 'English' selected. There are three input fields: 'User Email Address' containing the placeholder text 'My RotemNetWeb User Email address', and 'Password' which is empty. A blue 'Login' button is positioned below the password field. At the bottom, there are two links: 'Not registered yet? [Sign Up Now](#)' and '[Forgot Password](#)'.

- b. Click **Sign Up Now**.
- c. Fill out the fields and click **Sign Up**.
- d. Proceed to Step 2.

2. Disconnect the computer screen from the CommBox and reconnect it to a computer (alternatively use a different computer).
3. Sign in (using the email address and password that you used during activation) to the CommBox via the web at <https://www.rotemnetweb.com/>.

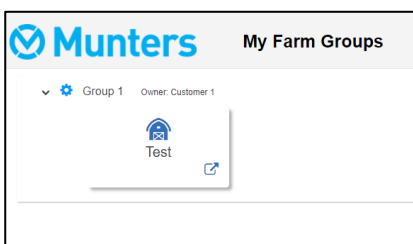

Figure 29: My Farm Groups

4. Click the gear icon . The following screen appears listing the active users.

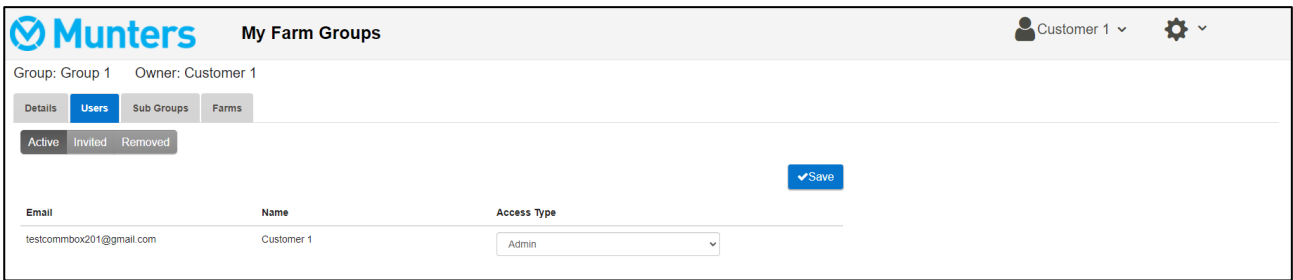

Figure 30: Active Users Screen

5. Click Invited.

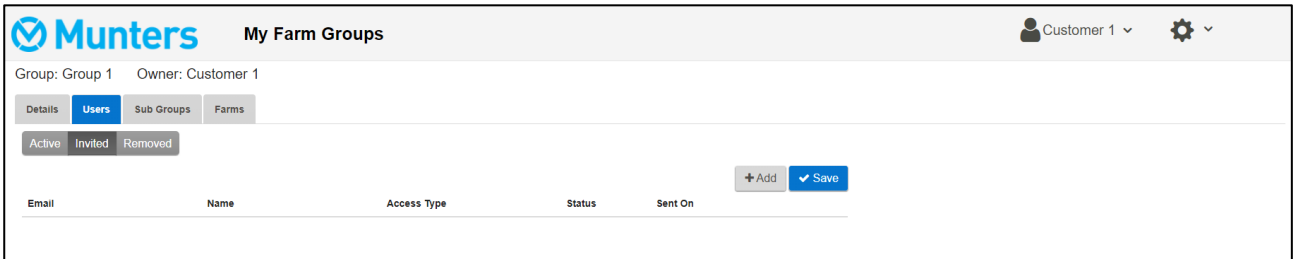

Figure 31: Add a New User Screen

6. Click Add.

- a. Fill out the fields.
- b. Define the user privileges (see below for details).
- c. Click Invite. The invitee receives the following email:

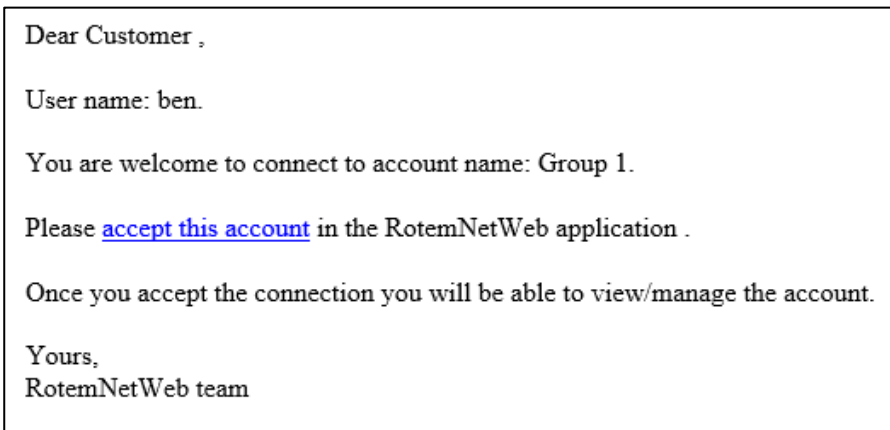

Figure 32: Email Invitation (Example)

5.3.2 DEFINING USER PRIVILEGES

Defining the privileges defines what functions the user can perform in both the CommBox and in the GreenApp.

• **CommBox User Rights:**

- ♦ Admin: User can edit all unit parameters including functions related to farm settings and farm ownership.
- ♦ Read/Write: User can edit all unit parameters but cannot perform any functions related to farm settings. (Farm Settings do not appear for users having Read/Write access).

- ◆ Read Only: User can only view the CommBox units' parameters; no changes can be made.
- ◆ Unauthorized: TBD. (Currently used as read only)
- ◆ Support: TBD. (Currently used as read only)
- **Web App User Rights:**
 - ◆ Farm Owner/Admin: User can edit all unit parameters including functions related to farm settings (including attaching a farm to a group) and inviting new users.
 - ◆ Read/Write: User can edit all unit parameters but cannot perform any functions related to farm settings (not visible).
 - ◆ Read Only: User can only view the units' parameters; no changes can be made.
 - ◆ Unauthorized: TBD. (Currently used as read only)
 - ◆ Support: TBD. (Currently used as read only)

5.4 Local Log In

In the event that:

- You restart your system
- CommBox logs off (this can happen automatically if you are not using system)
- Power goes off

you need to log on to the CommBox locally. The username and password of this login are different from the ones used when logging on to the Web.

Figure 33: Local Log In

- Enter the user name and password. The defaults are:
 - User name: "Farm Owner"
 - Password: "admin"

NOTE The user name cannot be changed. You can change the password after logging in.

NOTE After logging in locally, you will need to log in to the Web.

6 RotemNet Web

The following sections describe how to use the RotemNet Web functions. Controller functions are described in the product manuals.

- Sign In
- My Farm Groups
- RotemNet Farm Management
- RotemNet Web Functionality
- Software Upgrade
- About Tab

6.1 Sign In

There are two ways to sign in:

- Standard Login
- Private Server

6.1.1 STANDARD LOGIN

1. Go to RotemNetWeb.Com.

ROTEM[®]
RotemNet Web

Selected Region
AMERICA

Language
English

User Email Address
My RotemNetWeb User Email address

Password

Login DEMO

Not registered yet? [Sign Up Now](#)
[Forgot Password](#)

2. From the drop-down list, select the region closest to you. Proper selection is required to ensure faster response time.

ROTEM®
RotemNet Web

Selected Region

AMERICA

ASIA

AMERICA

CHINA

EUROPE

AFRICA

AUSTRALIA

PRIVATE

My RotemNetWeb User Email address

Password

Login DEMO

Not registered yet ? [Sign Up Now](#)
[Forgot Password](#)

3. Enter the email address and password, and click Login.

After signing in, the [My Farm Groups](#) screen appears:

6.1.2 PRIVATE SERVER

If your farm is connected to a private server system:

1. Click Private from the Selected Region. The following screen appears.

ROTEM®
RotemNet Web

Selected Region

PRIVATE

Navigate to your private server

example: https://www.myserver.com Navigate

Language

English

User Email Address

My RotemNetWeb User Email address

Password

Login DEMO

Not registered yet ? [Sign Up Now](#)
[Forgot Password](#)

2. Enter the server information.

NOTE Dealers provide this information, if relevant.

- After signing in, the [My Farm Groups](#) screen appears:

6.2 My Farm Groups

Click the My Farm Groups to access all groups to which you are participating in, in any capacity. The screen shows the groups and their status (on-line/off-line).

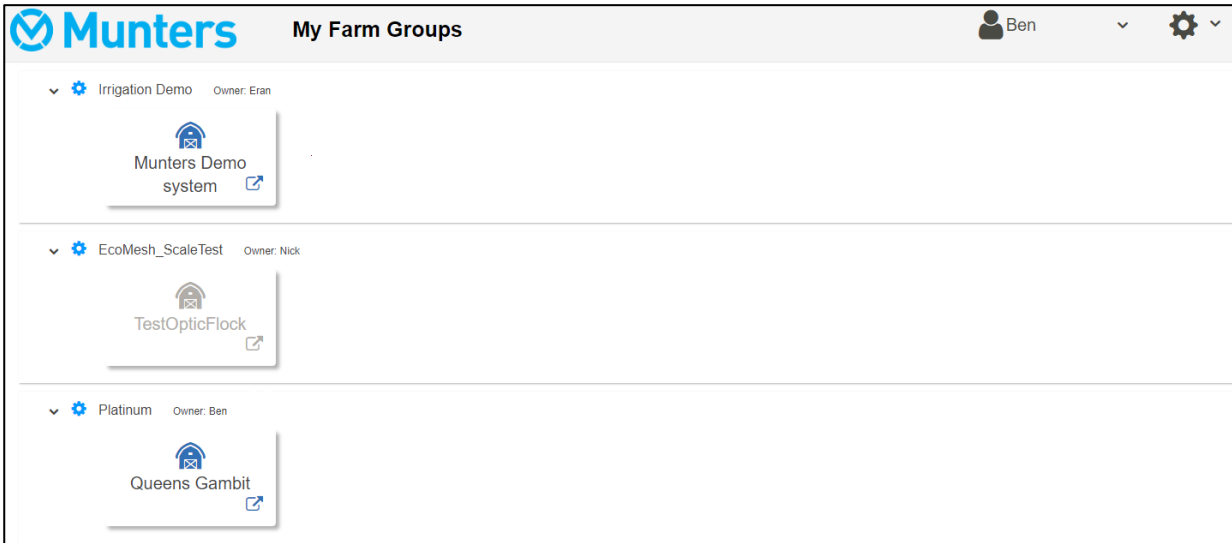

- Click any icon to go to the group's farms (refer to RotemNet Farm Management, page 36).
- Click the settings icon  to view and manage the group's users and farms.
- You can reach this screen from the dropdown menu:

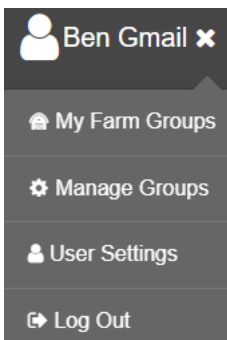

Figure 34: User Group Access

6.2.1 DETAILS (OPTIONAL)

Fill in details about the group as required.

Group Name	Group Owner	Created On
<input type="text" value="Irrigation Demo"/>	Eran Alon	04/10/2021 13:27

Comments

6.2.2 USERS

Click the Users tab to manage all group users.

6.2.2.1 Existing Users

Munters My Farm Groups

Group: Irrigation Demo Owner: Eran Alon

Details **Users** Sub Groups Farms

Active Invited Removed

Email	Name	Access Type	
Eran.Smith@email.com	Eran	Admin	
Nick.Smith@email.com	Nick	Admin	
Eran.Smath@email.com	Eran	Read Only	

- On this screen, delete users or change the permissions of existing users.

6.2.2.2 New Users

New users who are not part of the system must first sign up before being invited. If the user has an existing email address in the RotemNet Web system, go to Inviting the New User.

6.2.2.2.1 Creating a New User

1. Have the user go to rotemnetweb.com.

ROTEM®
RotemNet Web

Selected Region
AMERICA

Language
English

User Email Address
My RotemNetWeb User Email address

Password

[DEMO](#)

Not registered yet ? [Sign Up Now](#)
[Forgot Password](#)

2. Click **Sign Up Now**.

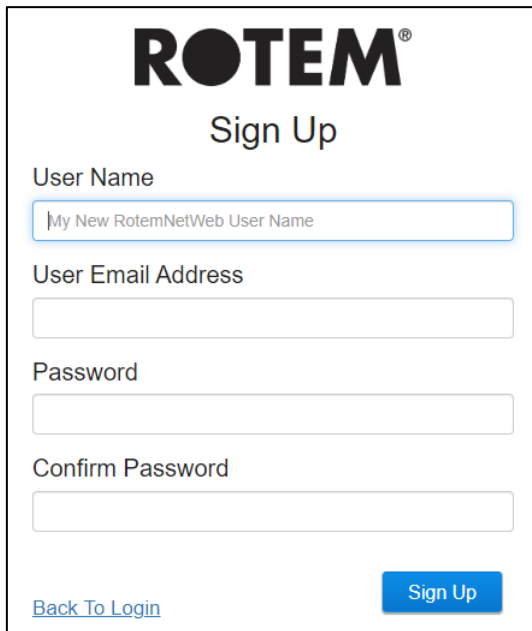

ROTEM[®]
Sign Up

User Name

User Email Address

Password

Confirm Password

[Back To Login](#)

3. Fill in the fields and click **Sign Up**.

6.2.2.2.2 Inviting the New User

Once the user has created an account, the administrator goes to the User screen.

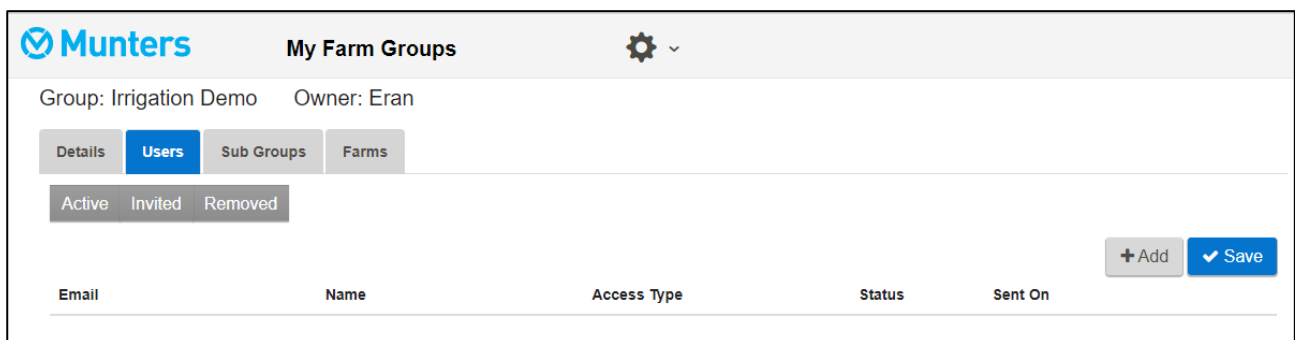

Munters My Farm Groups 

Group: Irrigation Demo Owner: Eran

Details **Users** Sub Groups Farms

Active Invited Removed

Email	Name	Access Type	Status	Sent On

1. Click **Add**.

2. In the Email field, enter the new user's email address. This address must be registered. See the following sections for details on creating a user.

3. Define the Access Type (permissions).

4. Click **Invite**.

The user will receive an email asking him/her to accept the invitation.

6.2.3 FARMS

The Farms screen lists the farms in this group.



6.2.4 MANAGE GROUPS

Manage Groups enables many of the same functions as the My Groups screen. In addition, you can create new groups from this page.

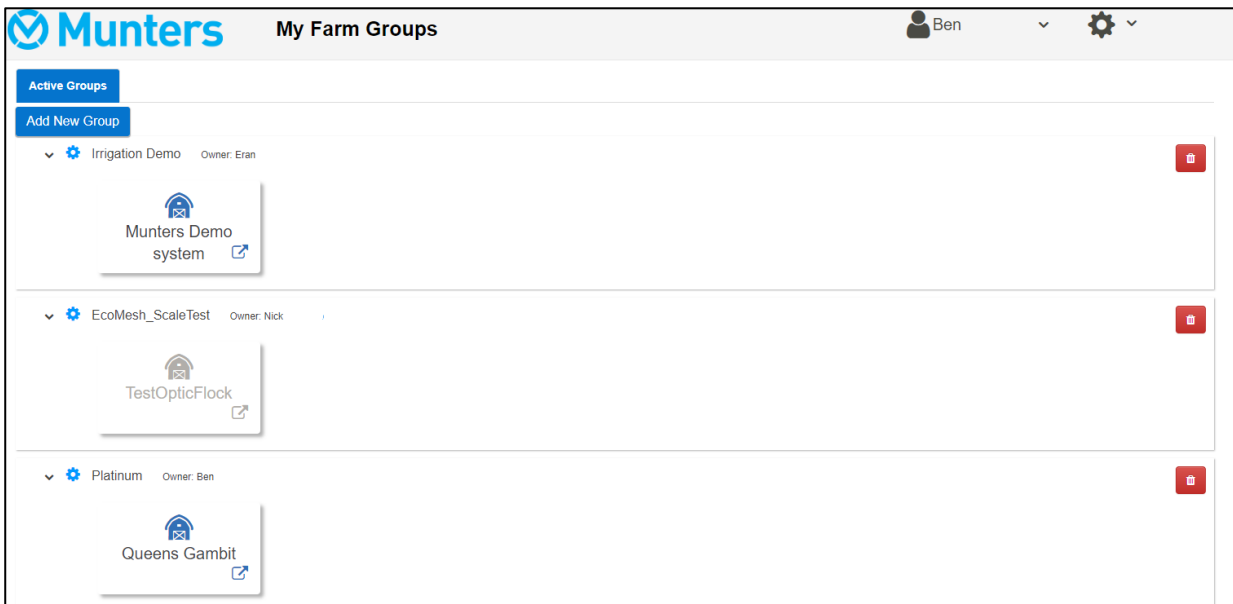

1. To create a new group, click Add New Group. Fill in the fields. A

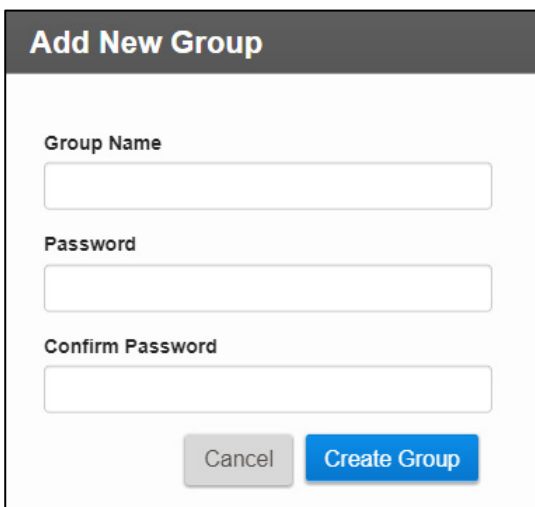

The screenshot shows the 'Add New Group' form. It has a dark grey header with the text 'Add New Group'. Below the header, there are three text input fields: 'Group Name', 'Password', and 'Confirm Password'. At the bottom of the form, there are two buttons: a grey 'Cancel' button and a blue 'Create Group' button.

Figure 35: Add New Group screen

2. After creating the group, add farms to the group. Go to the Farm Settings screen.
NOTE Only a farm owner/administrator connected to a farm locally can attach the farm to a group.

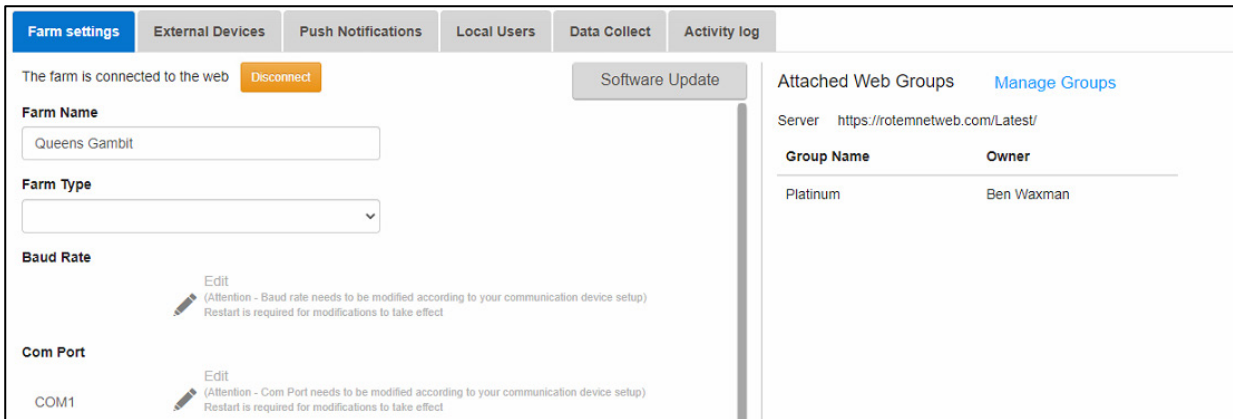

3. Click Manage Groups and attach the farm to a group.

6.2.5 USER SETTINGS

This screen defines how information appears on the screen. In Farm Owner, select

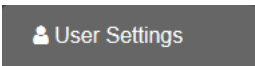

. The following screen appears.

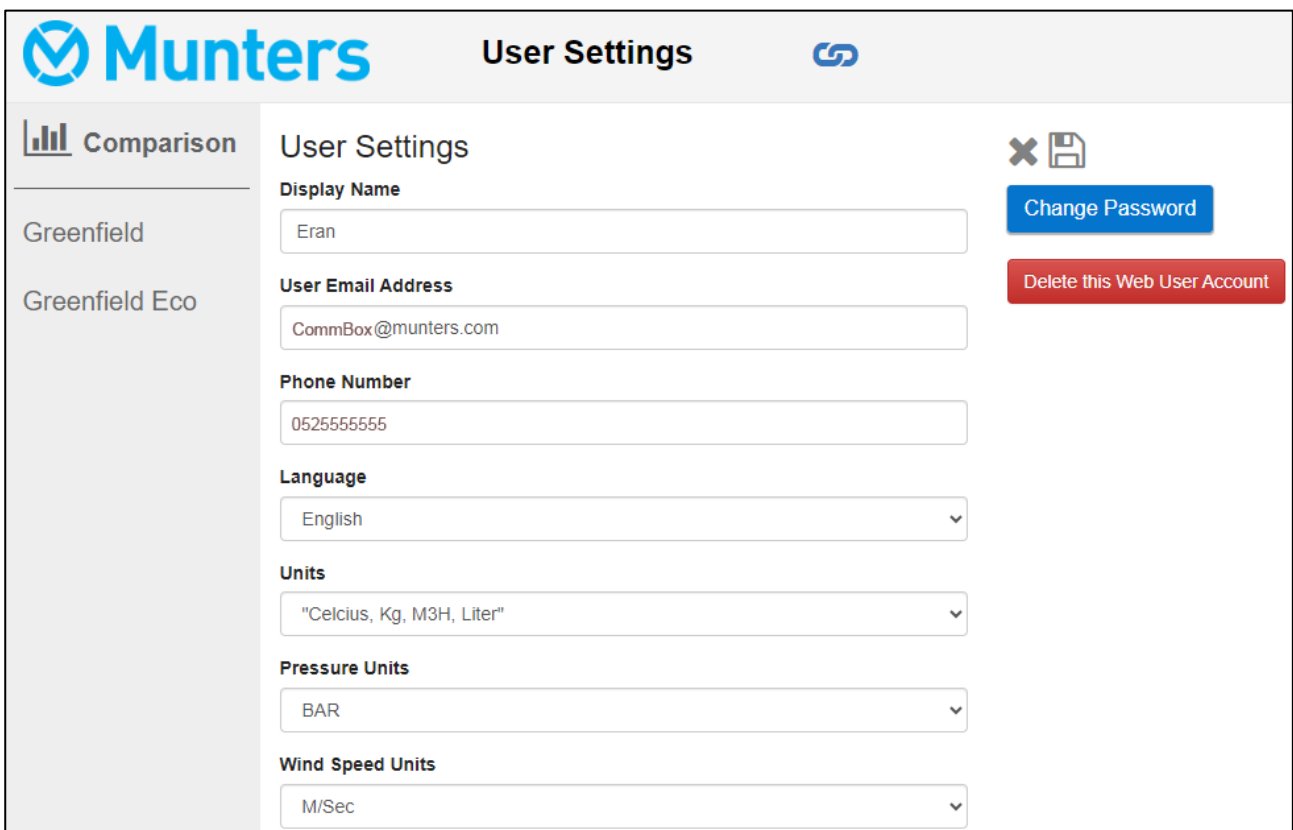

- To edit, click . Fill in the following fields as required.
 - Display name: Name that appears on the User Setting screen.
 - User email address
 - Phone number

- Language: Chose from the drop-down list
- Unit types: Metric or English
- Temp Units: Celsius or Fahrenheit
- Pressure Units
- Wind Speed Units
- Disable or enable standby by mode (if the latter, define the amount of time that needs to pass before the mode is activated).
- Click  to save any changes.

6.3 RotemNet Farm Management

- Dashboard
- RotemNet Screen Appearance

6.3.1 DASHBOARD

After signing in, an initial screen appears. The screen that appears depends on the controllers connected to the CommBox.

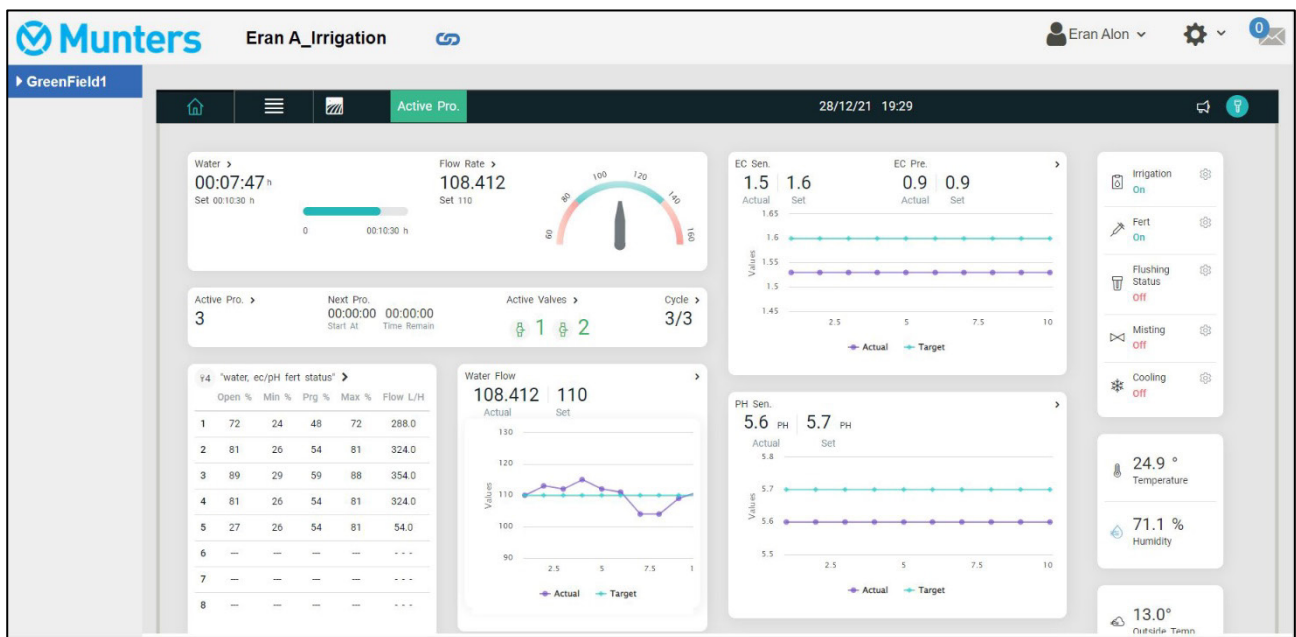





Figure 36: Green Field Dashboard

- Click on  to go to that controller functionality.
- Click on  to configure RotemNet Web functionality.
- Click on  to configure the user definitions.

6.3.2 ROTEMNET SCREEN APPEARANCE

The screen appearance depends on how the user connects to the CommBox, as a local user or via the internet. Users connected locally have access to additional functionality.

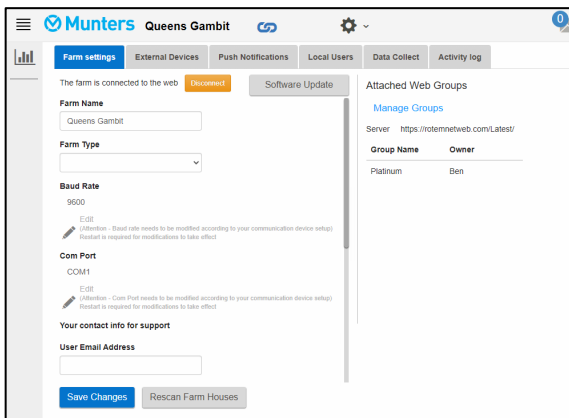

Figure 37: Local Connection

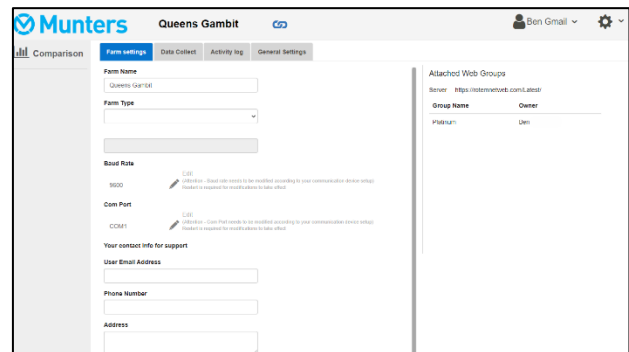

Figure 38: Web Connection

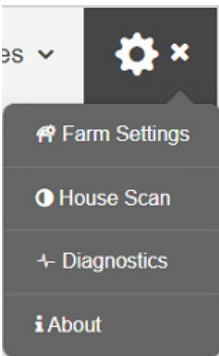

Figure 39: Local Connection Settings

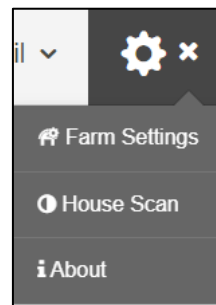

Figure 40: Web Connection Settings (administrator)

In addition, when connected via the web, the user has easy access to his/her groups (Refer to My Farm Groups, page 31).

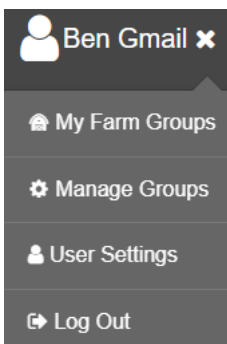
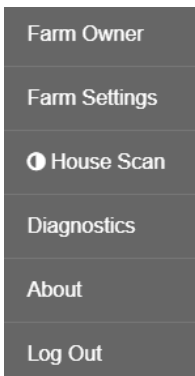

Figure 41: User Group Access

6.4 RotemNet Web Functionality

The following section describes the RotemNet Web functions.



- Farm Settings Tab
- House Scan Tab
- Diagnostics Tab
- About Tab

NOTE Only the farm owner can view the Farm Owner, Farm Settings, and House Scan tabs.

6.4.1 FARM SETTINGS TAB

- Farm Settings
- External Devices
- Push Notifications
- Local Users
- Data Collect
- Activity Log

NOTE The “Push Notifications” and “Local Users” tabs appear only on a computer screen connected directly to the CommBox.

6.4.1.1 Farm Settings

Use this screen to define functions related to CommBox's connection to your farm.

- This function appears both for local and web access connections.

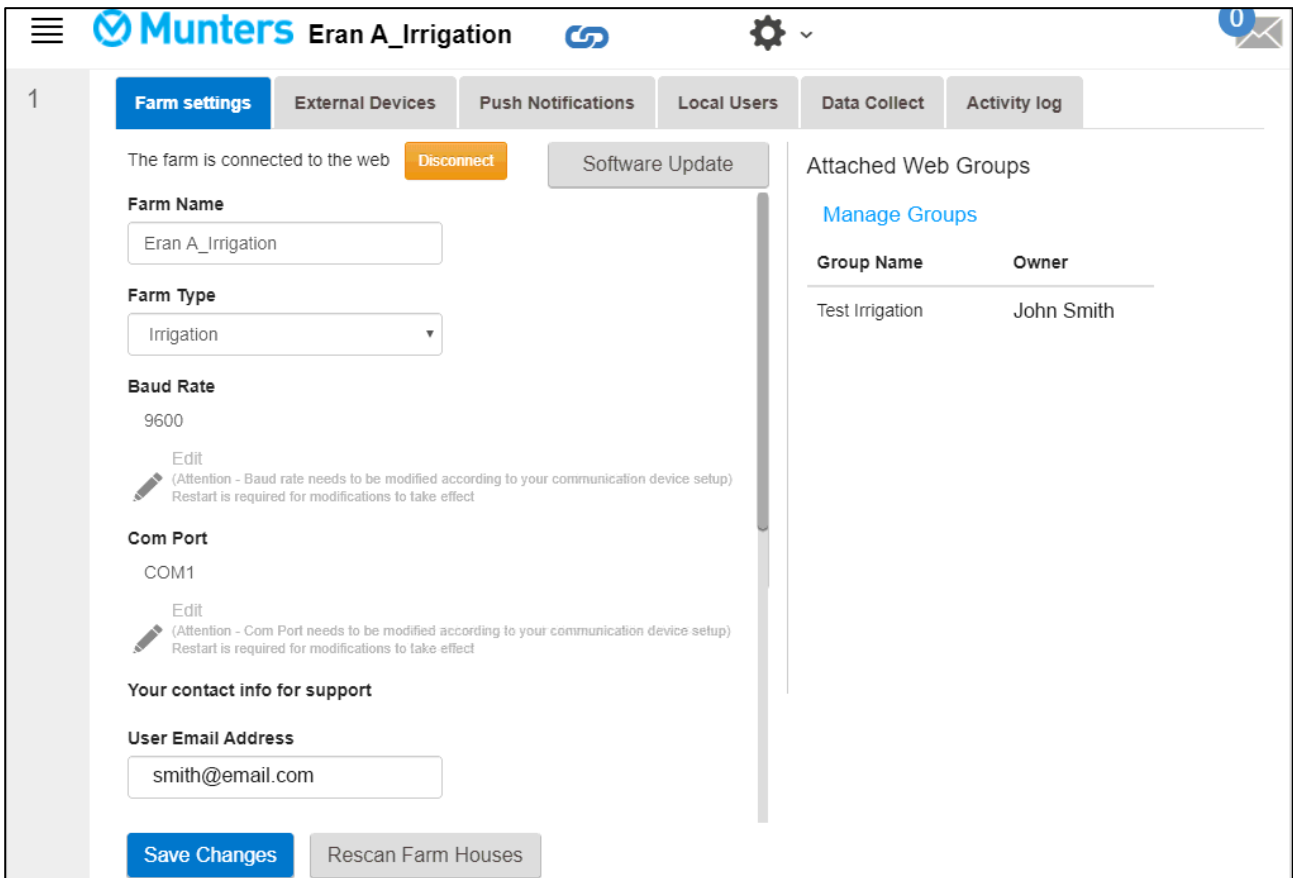

Figure 42: Farm Settings Screen

- **Farm Name:** This is the name that appears on your screen.
- **Connect/Disconnect:** This function enables disconnect from the current farm from the internet and reconnecting it via the Log-in screen).

NOTE This function only appears on screens locally connected to the CommBox.

- **Farm Type:** Poultry Pigs, or Irrigation. Make sure that the definition matches the CommBox type!
- **Baud rate:** This rate must be the same throughout the network.
- **Com Port**
- **Contact information (optional):** This information will be used by Munters to contact users if there is a need; for example to inform you of an update. The information will not be distributed to any outside parties whatsoever.
- **Date and Time/Time Zone:** Edit as required.
- **Number of Houses to be Scanned:** Scanning tests communication to the houses. If you wish to scan all houses or individual houses, click the relevant house number. Click Rescan farm houses to complete the scan.
 - You can name the houses.
- Click **Save Changes**.

- System Update: Refer to Software Upgrade.

6.4.1.2 External Devices

Not applicable to irrigation systems.

6.4.1.3 Push Notifications

- This function appears both for local and web access connections.

CommBox can send push notifications to multiple email addresses. These emails list:

- House/controller number
- Alarm time and date
- Alarm description

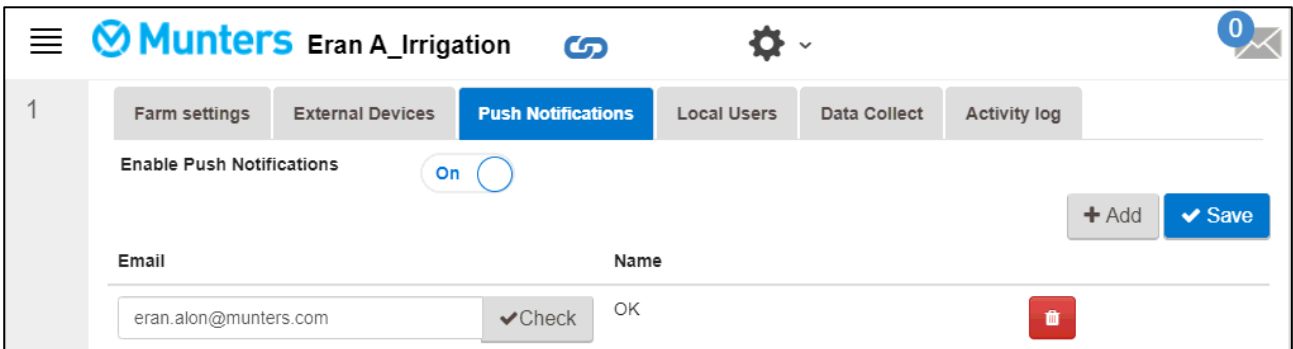

Figure 43: Push Notifications Screen

- Enter an address, click Check, Add, and then Save.

6.4.1.4 Local Users

NOTE This tab and screen only appear when connected directly to the CommBox (meaning not via the web).

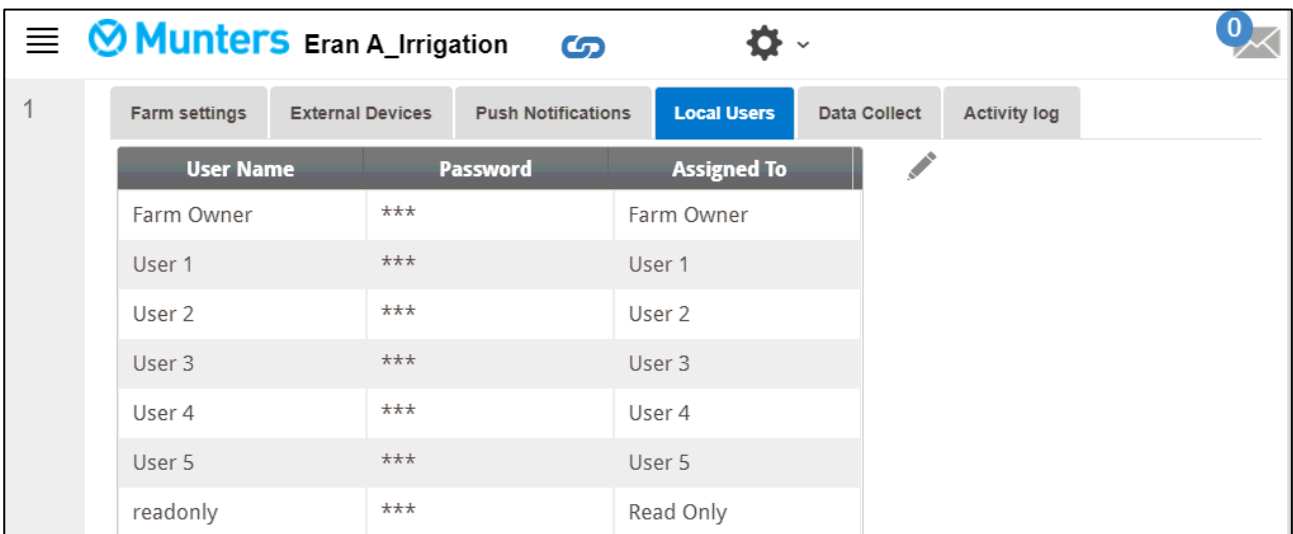

Figure 44: Password Definitions Screen

This screen lists pre-assigned user names and passwords.

- Each user name and password is the same. For example, User 1's password is User 1. User 2's password is User 2.
- The Farm Owner can edit these names, passwords, and to whom they are assigned.

6.4.1.5 Data Collect

Refer to Appendix B: Data Collection, page 49.

- This function appears both for local and web access connections.

6.4.1.6 Activity Log

This screen displays the history of events connected to the CommBox. Under Event, Sub Event, User, and Cmd ID you can select filters to narrow down the results.

- This function appears both for local and web access connections.

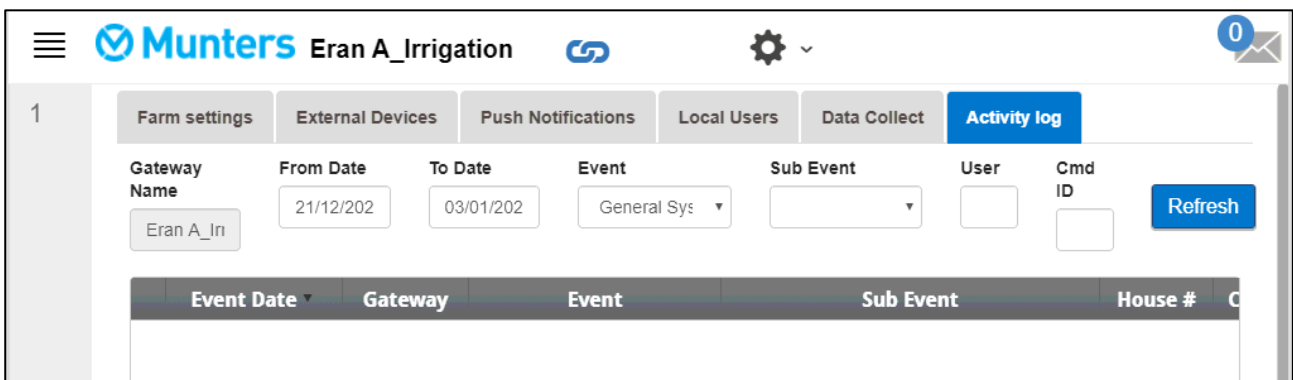

Figure 45: CommBox Events

Refer to Appendix A: Generating an Activity Log, page 47 for detailed information on this function.

6.4.1.6.1 General Settings





Refer to Appendix B: Data Collection, page 49.

- This function appears in web access connections only.

6.4.2 HOUSE SCAN TAB

The House Scan screen:

- Shows the results of the house scan.
- Show the controller type and software version used in each house.

Eran A_Irrigation



Started to scan for houses in farm Eran A_Irrigation

Scan In Progress

Scan Progress

House	1
Ping	Passed
Analyze	Passed
Load Controller Configuration	Passed
Load Controller Data	In Progress 
Controller Type	Irrigation GreenField
Controller Version	3.8.4

Figure 46: Scan Example

6.4.3 DIAGNOSTICS TAB

CommBox 4.6.0.35 includes a basic diagnostics package.

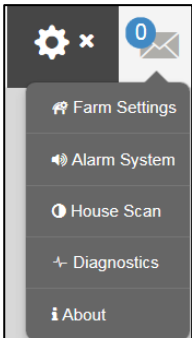

- On the Activation screen click Diagnostics. The following screen appears.

Diagnostics

Go Back

Device Details

Serial Number TSBG07009328 ✓ **Version** 1.50.8.46035

Diagnostic Tests

Test Name	Test Instruction		Pass	Fail
Comm Port Connection	<ul style="list-style-type: none"> • Connect Serial RS232 Cable From Controller To Comm Port 1 At The Comm-Box. • Go To Communication Menu (Under Install Menu On PP Controller System in Touch Controller). • Set The House Number to 1 and Baud Rate To 9600. • Press the Run Test Button. • Repeat Steps 1 to 4 for Comm Port 2 	Com 1 Connection 9600 ▼ House Number <input style="width: 50px;" type="text" value="1"/> <input type="checkbox"/> Repeatable	Run Test	
		Com 2 Connection 9600 ▼ House Number <input style="width: 50px;" type="text" value="1"/> <input type="checkbox"/> Repeatable	Run Test	
Internet Connection	<ul style="list-style-type: none"> • On the Comm-Box, connect the LAN cable to LAN Port 1. • Click Run Test. • Repeat for LAN Port 2. 		Run Test	
Connection To Rotem WEB System	<ul style="list-style-type: none"> • On the Comm-Box, connect the LAN cable to one of the LAN ports. • Click Run Test. 		Run Test	
Latest Image Version Installed	<ul style="list-style-type: none"> • This test verifies that the last released image is installed in this Comm-Box • This test is performed automatically 		Run Test	
TeamViewerID for the Remote Support	<ul style="list-style-type: none"> • On the Comm-Box, connect the LAN cable to one of the LAN ports. • Click Run Test." 		Run Test	
Total Results:				

Speed Test

CAUTION When switching from Diagnostics mode to Normal mode, there could be a System Issue with closing communication port. If there is a service interruption, reboot the CommBox.

- Use this screen and the information it supplies when speaking with technical support.
- Diagnostic Tests enables the following tests:
 - Lan test
 - Internet tests
 - Support tests
 - COM Port test. This option can be used to test the communication between the CommBox and any house. Enter the number of the house to be tested. This test has two options:
 - Standard. This test shows the ping time between the CommBox and the selected controller. Either a number appears or there is a failure.

Test Name	Test Instruction			Pass	Fail
Comm Port Connection	<ul style="list-style-type: none"> • Connect Serial RS232 Cable From Controller To Comm Port 1 At The Comm-Box. • Go To Communication Menu (Under Install Menu On PP Controller System in Touch Controller). • Set The House Number to 1 and Baud Rate To 9600. • Press the Run Test Button. • Repeat Steps 1 to 4 for Comm Port 2 	Com4 Connection 9600 House Number 1 <input type="checkbox"/> Repeatable	Run Test	✓ 1.2609012	

- Repeatable. This test enables verifying that the controller’s communication card (RS232 or RS485) is sending and receiving signals. Click the Run Test icon and examine the controller communication card to ensure that its test LEDs are flashing.

Test Name	Test Instruction			Pass	Fail
Comm Port Connection	<ul style="list-style-type: none"> • Connect Serial RS232 Cable From Controller To Comm Port 1 At The Comm-Box. • Go To Communication Menu (Under Install Menu On PP Controller System in Touch Controller). • Set The House Number to 1 and Baud Rate To 9600. • Press the Run Test Button. • Repeat Steps 1 to 4 for Comm Port 2 	Com4 Connection 9600 House Number 1 <input checked="" type="checkbox"/> Repeatable	Run Test	✓ 27.481028	

- Enables a speed test.

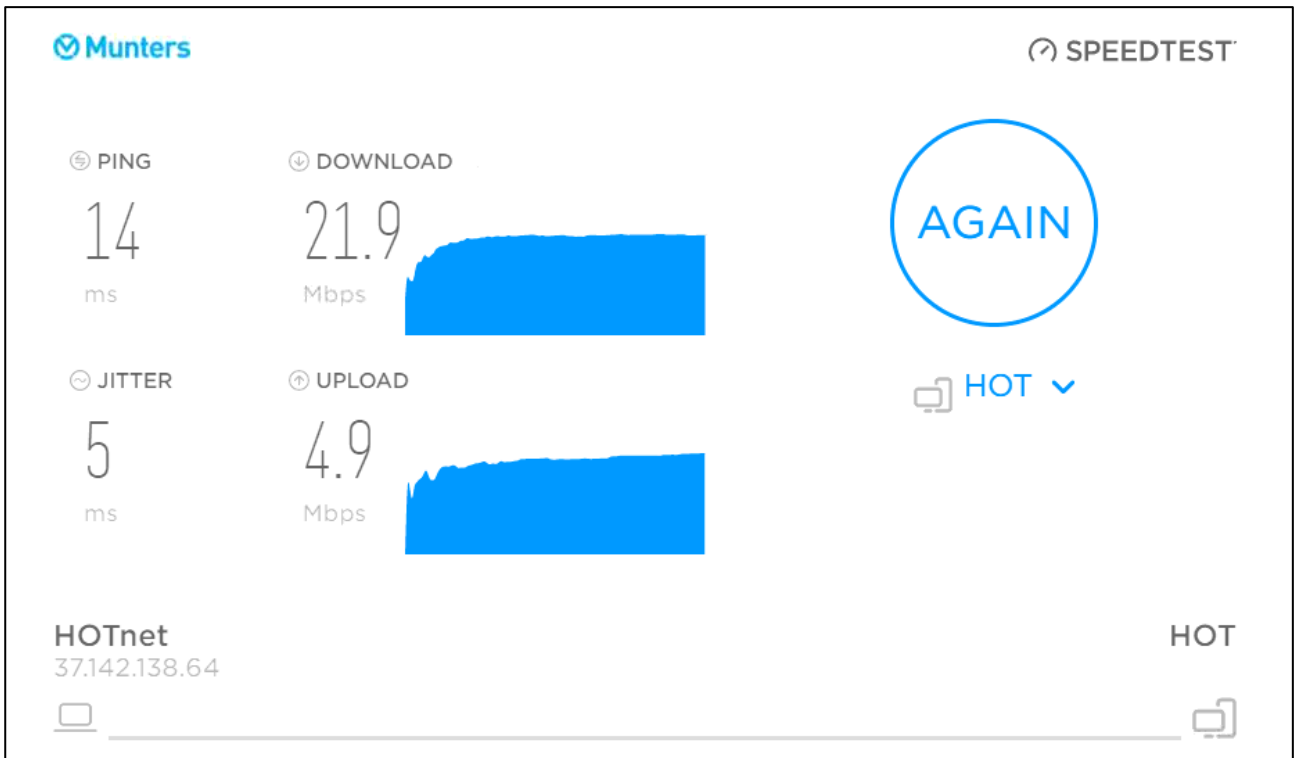

Figure 47: Speed Test

6.5 Software Upgrade

You can upgrade certain software programs from the Web application.

- GreenField App software
- Web application
- CommBox software

NOTE CommBox can be updated locally only; it cannot be updated remotely. The System Update button does not appear in remote connections.

NOTE You cannot upgrade product software! Upgrade your product software using the procedures given in the product manuals.

NOTE If you are using a disk on key start here. If you are updating your CommBox via the web, go to step 4.

1. Request the software upgrade from your dealer. You will be sent (via email, web transfer, etc.) a UPD file.

- Place the file on a disk on key/flash drive.
- Place the disk on key/flash drive into the CommBox' USB port.

2. In the web application, click the Farm Settings tab. The following screen appears.

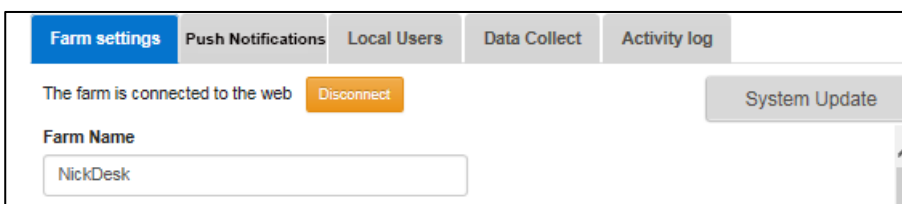

Figure 48: Farm Settings System Update

3. Click System Update. The following screen appears:

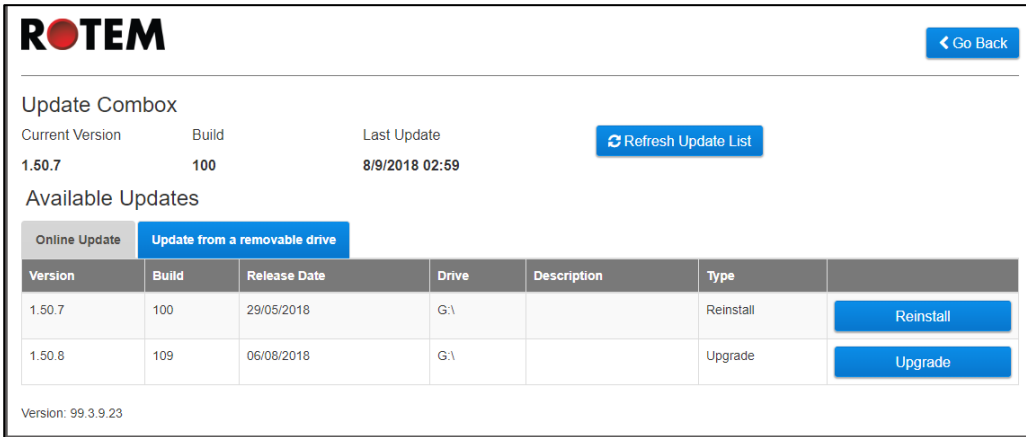

Figure 49: Update Software

- Users updating online: Click Online Update and choose the required software version.
- User updating using a flash drive: Click Update from a removable drive and choose the required software version.

NOTE If you did not place the disk on key in the USB port or if the disk does not contain a program, an error message appears.

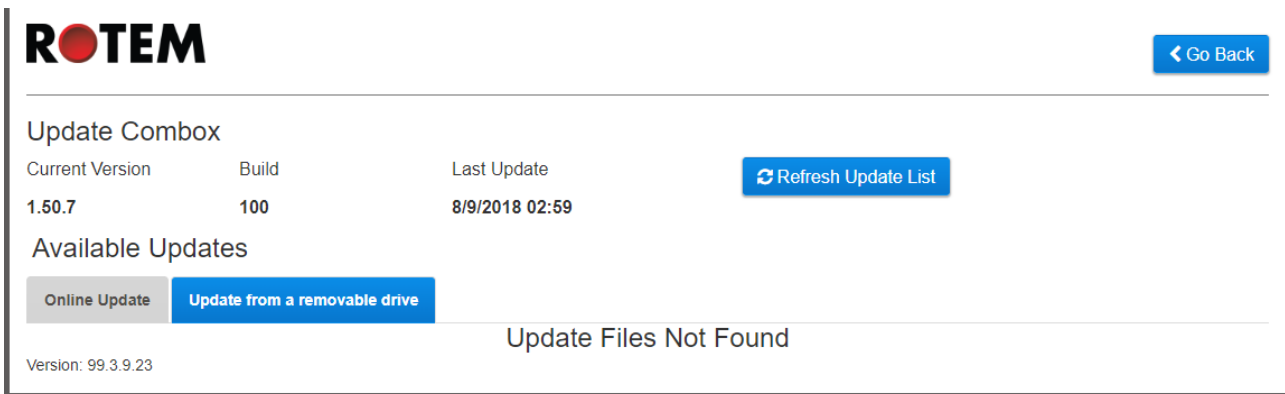

Figure 50: Error Message

6.6 About Tab

This screen displays the product and software version. Send this information to technical support in the event that you require assistance. The Support ID enables remote technical support from Munters or from your dealer.

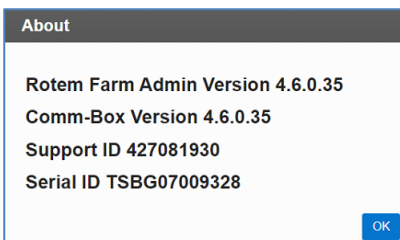
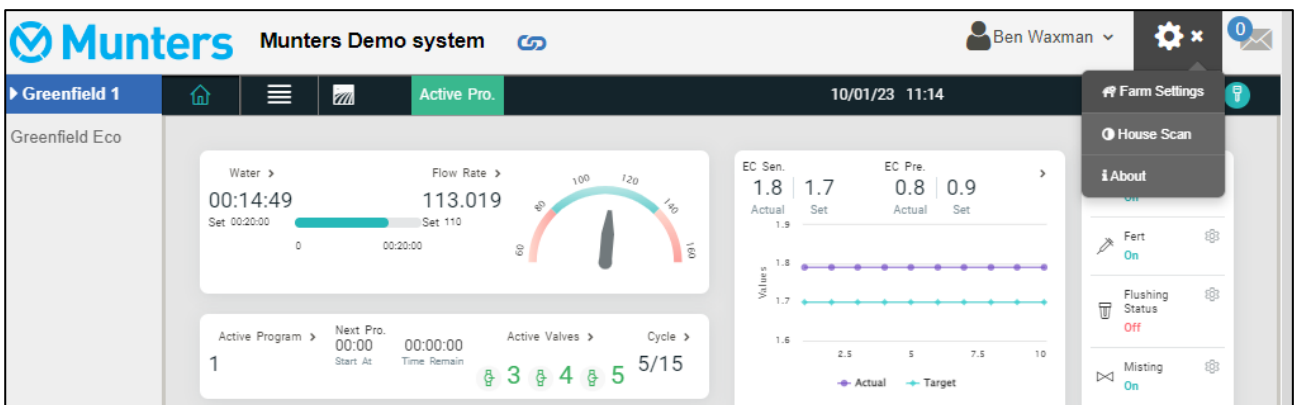

Figure 51: Tech Support Screen

7 Appendix A: Generating an Activity Log

The following section details how to use the Activity Log, in particular how to determine who made changes to the controllers' settings. Please note:

- These inquiries can only be made via the web. Local connections or connecting via TeamViewer do not support this function.
 - Only changes made via the web are listed! Changes made locally by the farm owner or administrator are not listed.
 - Only administrators can perform this function.
1. Connect to a farm via www.rotanetweb.com.



2. Under the settings icon, click Farm Settings.

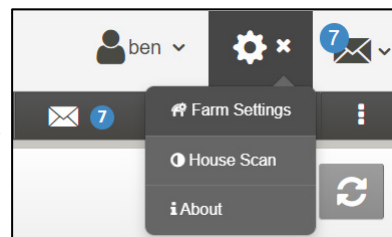

3. Click the Activity Log tab.

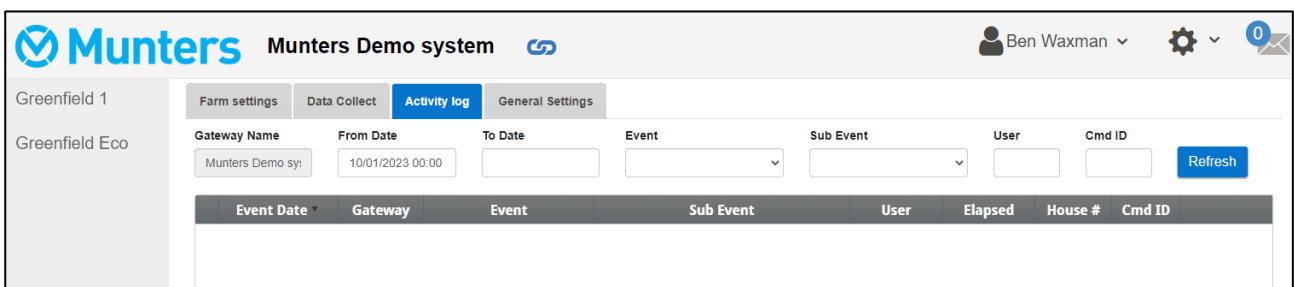

4. Define as needed:

- Gateway Name: (farm name that the user chose): Read only.
- From/To: Define the time frame.
- Event:

- To see all events, leave this field empty.
- To see who made changes to the controller settings, choose Save Farm Data from the dropdown list.
- Sub Event: Select if required.
- User: If you are looking for a specific person's activities, type in the user name.
- Cmd ID: If you are looking for a specific change in controller settings, type in the command ID.

Farm settings		Data Collect	Activity log	General Settings						
Gateway Name	From Date	To Date	Event	Sub Event	User	Cmd ID				
Munters Demo sy:	10/01/2023 00:00		Save Farm Data					Refresh		
Event Date	Gateway	Event	Sub Event	User	Elapsed	House #	Cmd ID			
10/01/23 11:33:03	Munters Demo system	Save Farm Data	Web Request Ended	Ben Waxman	2.353 sec	1	15	show info		
10/01/23 11:32:11	Munters Demo system	Save Farm Data	Web Request Ended	Ben Waxman	813 ms	1	9	show info		
10/01/23 11:31:57	Munters Demo system	Save Farm Data	Web Request Ended	Ben Waxman	2.776 sec	1	101	show info		

NOTE For information on the Command IDs, consult with technical support.

8 Appendix B: Data Collection

8.1 Centralized Collection

NOTE Only use the Centralized Collection function after consulting with Munters technical support.

- Only the group owner or administrator can define the General Settings. The following tab does appear on any other user's screen.
- The General Settings page is an option. If data upload is to a local server only, leave these fields blank and go to Defining the FTP/SFTP server.

1. In the settings icon, select Farm Settings.

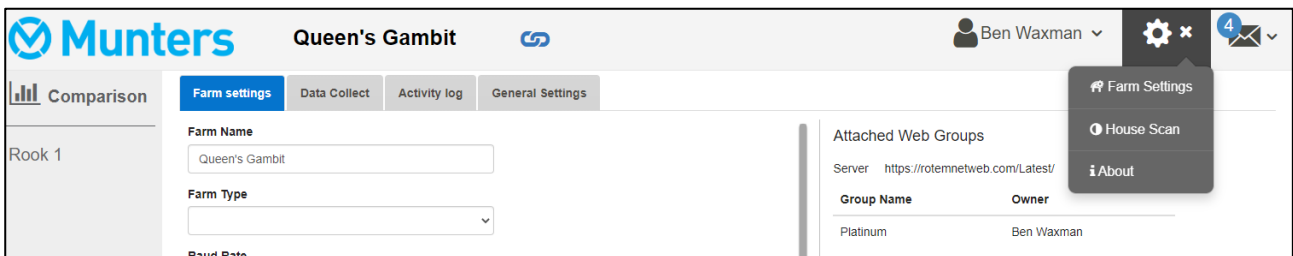

2. Go to Farm Settings > General Settings.

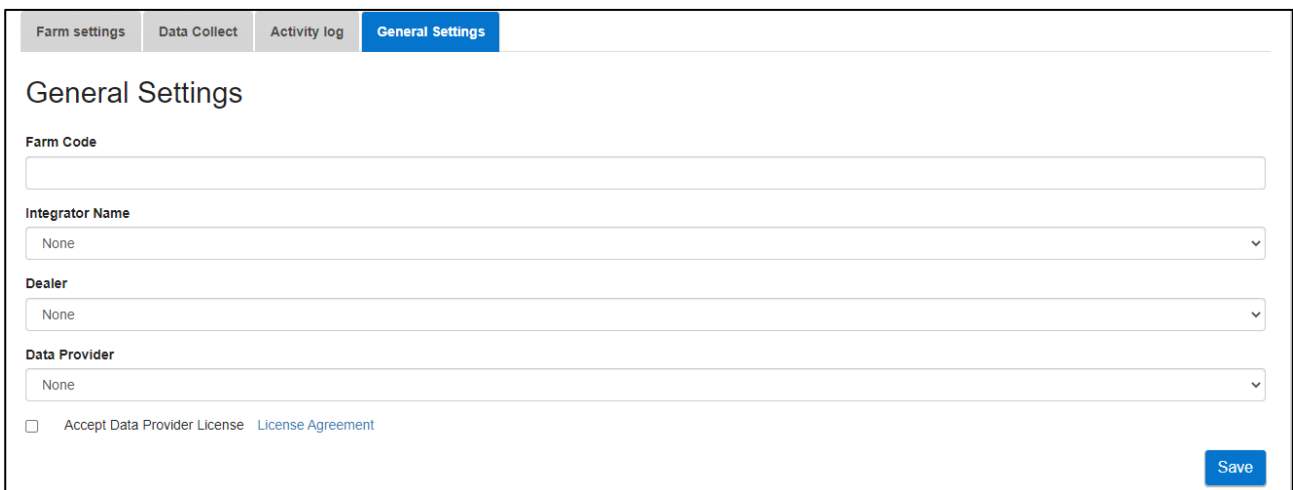

3. Enter the data as follows:

- Farm Code: This is a code provided by the integrator used to identify the farm.
- Integrator Name: From the drop-down list, select the required name.
- Dealer: From the drop-down list, select the required dealer name.
- Data Provider: From the drop-down list, select the required data provider.
- Accept Data Provider License. Mark this box. This box must be checked to enable centralized data collection.

NOTE This acceptance is saved.

Farm settings	Data Collect	Activity log	General Settings
---------------	--------------	--------------	-------------------------

General Settings

Farm Code

Integrator Name

Dealer

Data Provider

Accept Data Provider License [License Agreement](#)

Accepted on 29/12/2022 14:38 By John Smith

4. Click the Data Collect Screen. Refer to the following section.

8.2 Defining the FTP/SFTP server

Use this function to enable data collection to your FTP/SFTP site.

NOTE *Data Upload Allowed* appears if the General Settings fields are filled out and Data Provider License accepted. If the fields are filled out but the license is **NOT** accepted data, upload is disabled.

Farm settings External Devices Push Notifications Local Users **Data Collect** Activity log

Data Upload Settings Log

▼ Data Upload Settings
Data Upload Allowed

Farm name for collect

License key

Expired date

Allow to change settings

FTP SFTP ?

FTP Remote Server Details

Host Address

Port Number

Target Folder

User Name

Password

▼ Collect Preferences

Auto Collect

Alarm History VFT

Collect Alarms every 1 minute

Select Output File Formats: xml MTech

Define The Data Collection Interval min.

Select Houses

House Number

House 1

Save

- Data Upload Settings:
 - Check **Allow to change settings** to enable editing the page.
 - Select **FTP** or **SFTP** and check the box.
 - License key: This is a read-only field. The field is filled in automatically if you fill in the General Settings fields.
- FTP/SFTP Details: Fill in the fields as required.
- Collect Preferences:
 - Under **Select Houses**, select at least one house to enable changing Auto Collect settings.
 - Check Alarm History, VFT, and Collect Alarms every 1 minute as required.

CAUTION *Only mark the Alarm History, VFT, and Collect Alarms checkboxes if you are uploading data to a centralized collector. Anyone using a private FTP server must leave these boxes unchecked!*

- Select the output file format.
- Define the collection interval.

9 Warranty

Warranty and technical assistance

Munters products are designed and built to provide reliable and satisfactory performance but cannot be guaranteed free of faults; although they are reliable products they can develop unforeseeable defects and the user must take this into account and arrange adequate emergency or alarm systems if failure to operate could cause damage to the articles for which the Munters plant was required: if this is not done, the user is fully responsible for the damage which they could suffer.

Munters extends this limited warranty to the first purchaser and guarantees its products to be free from defects originating in manufacture or materials for one year from the date of delivery, provided that suitable transport, storage, installation and maintenance terms are complied with. The warranty does not apply if the products have been repaired without express authorisation from Munters, or repaired in such a way that, in Munters' judgement, their performance and reliability have been impaired, or incorrectly installed, or subjected to improper use. The user accepts total responsibility for incorrect use of the products.

The warranty on products from outside suppliers fitted to is limited to the conditions stated by the supplier: all claims must be made in writing within eight days of the discovery of the defect and within 12 months of the delivery of the defective product. Munters has thirty days from the date of receipt in which to take action, and has the right to examine the product at the customer's premises or at its own plant (carriage cost to be borne by the customer).

Munters at its sole discretion has the option of replacing or repairing, free of charge, products which it considers defective, and will arrange for their despatch back to the customer carriage paid. In the case of faulty parts of small commercial value which are widely available (such as bolts, etc.) for urgent despatch, where the cost of carriage would exceed the value of the parts, Munters may authorise the customer exclusively to purchase the replacement parts locally; Munters will reimburse the value of the product at its cost price.

Munters will not be liable for costs incurred in demounting the defective part, or the time required to travel to site and the associated travel costs. No agent, employee or dealer is authorised to give any further guarantees or to accept any other liability on Munters' behalf in connection with other Munters products, except in writing with the signature of one of the Company's Managers.

WARNING: In the interests of improving the quality of its products and services, Munters reserves the right at any time and without prior notice to alter the specifications in this manual.

The liability of the manufacturer Munters ceases in the event of:

- dismantling the safety devices;
- use of unauthorised materials;

- inadequate maintenance;
- use of non-original spare parts and accessories.

Barring specific contractual terms, the following are directly at the user's expense:

- preparing installation sites;
- providing an electricity supply (including the protective equipotential bonding (PE) conductor, in accordance with CEI EN 60204-1, paragraph 8.2), for correctly connecting the equipment to the mains electricity supply;
- providing ancillary services appropriate to the requirements of the plant on the basis of the information supplied with regard to installation;
- tools and consumables required for fitting and installation;
- lubricants necessary for commissioning and maintenance.

It is mandatory to purchase and use only original spare parts or those recommended by the manufacturer.

Dismantling and assembly must be performed by qualified technicians and according to the manufacturer's instructions.

The use of non-original spare parts or incorrect assembly exonerates the manufacturer from all liability.

Requests for technical assistance and spare parts can be made directly to the nearest [Munters office](#).

